

## **Douglas County Road Standards – Supplementary Definitions**

Supplementary Definitions and modifications to be added to list of definitions in DCC Title 14.98:

**AASHTO** – The American Association of State Highway and Transportation Officials

**Access point** – That location on a public road where a driveway or private road connects.

**ACP** – Asphalt Concrete Pavement as per WSDOT Standard Specifications.

**ADA** – Americans with Disabilities Act of 1990, as amended.

**BST** – Bituminous Surface Treatment

**CF** – Cubic feet

**Channelization** – The separation or regulation of conflicting traffic movements into definite paths of travel by the use of pavement markings, raised islands or other suitable means to facilitate the safe and orderly movements of both vehicles and pedestrians.

**Clear Zone** – The total roadside border area, starting at the edge of the traveled way, available for safe use by errant vehicles. The area may consist of a shoulder, a recoverable slope, a non-recoverable slope, and/or a clear run-out area. The desired width is dependent upon the traffic volumes, speeds, and roadside geometry.

**Consultant** – A person, partnership or corporation duly registered to practice professional engineering according to Washington State statutes, who is hired by the landowner or developer and is empowered to act as his agent.

**Control Zone** - That roadside area defined by the “Control Zone Distance Table”, found in Appendix 5 of the WSDOT Utilities Manual, within the road right-of-way in which placement of above-ground utility objects is controlled.

**County Road** – A right-of-way over which the public has a legal right of passage, and over which an automobile can be driven, and is not designated as a state highway, and is outside the boundaries of a city or town. Furthermore, the County shall have responsibility and authority over only such county roads that have been incorporated into the county road system via statutory authority, i.e., RCW 36.75.070, RCW 36.75.080, RCW 36.75.090, RCW 36.81, RCW 36.88, RCW 58.17 and RCW 36.89

**CSTC** – Crushed Surfacing Top Course as per WSDOT Standard Specifications.

**CY** – Cubic Yard

**Design Speed** – A speed determined for design and correlation of the physical features of a highway that influence vehicle operation: the maximum safe speed maintainable over a specified section of road when conditions permit design features to govern.

**DCC** – Douglas County Code section reference.

**DHV** – Design Hour Volume. Hourly traffic volume used for road design and capacity analysis, usually one or more peak hours during a 24 hour period. The DHV is typically the 30<sup>th</sup> highest hourly volume of the future year chosen for design. On the average rural road or arterial, DHV is about 15 percent of ADT; for urban areas, DHV is usually between 8 to 12 percent of ADT.

**Driveway**<sup>1</sup> – A private access way connected to a public road serving a single residential or commercial unit.

**Driveway, Joint Usage**<sup>2</sup> – A private access way connecting to a public road serving two adjacent residential or commercial units at a single point.

**Edge of Traveled Way** – The face of curb for roads that are, or will be constructed to urban standards and the edge of pavement (not including shoulders) for roads that are, or will be constructed to rural standards.

**Emergency Vehicle Access** – An improved easement providing access to structures for fire apparatus and other emergency vehicles as provided for in Section 902.2 of the Uniform Fire Code as adopted by Douglas County and meeting the requirements of a fire apparatus access road as per DCC 15.24.030.

**Encroachment** – Occupancy of county right-of-way by non-roadway structures or other objects of any kind.

**Geologist** – A practicing geologist licensed as a professional geologist pursuant to Chapter 18.22 RCW.

**Geometrics** – The arrangement of the visible elements of a road such as alignment, grade, sight distance, widths and slopes.

**HMA** – Hot Mix Asphalt

**Level of service** – A measure of traffic congestion along a roadway or at an intersection. Within Douglas County this is done with a two-part process – a ‘condition’ LOS and an ‘operational’ LOS. See “Douglas County Transportation Element” for details.<sup>3</sup>

**MPH** – Mile Per Hour

---

<sup>1</sup> This is a change from the definition currently in use.

<sup>2</sup> This is a new definition.

<sup>3</sup> This is a change from the definition currently in use.

**MUTCD** – The Manual on Uniform Traffic Control Devices

**Operating Speed** – Used for determination of sight distance. Operating speed should be equal to the P85 speed for existing facilities and be equal to the design speed for new facilities.

**Passing Sight Distance** – The minimum sight distance required for the driver of one vehicle to pass another safely and comfortably.

**Pavement Width** – The distance measured from face of curb to face of curb for curbed sections of roadway or the distance measured from outside edge of shoulder to outside edge of shoulder for shouldered sections of roadway.

**PC** – Point of Curvature

**PCC** – Portland Cement Concrete as per WSDOT Standard Specifications, or Point of Compound Curvature on alignment plans.

**P85 Speed or 85<sup>th</sup> Percentile Speed** – Based on speed studies, P85 speed is that maximum speed at which 85% of the drivers will choose to drive and feel comfortable based on the prevailing weather and traffic conditions for a particular section of road.

**PI** – Point of Intersection

**Primitive Road** – An opened, county-maintained right-of-way that meets the requirements of RCW 36.86.070. A primitive road has gravel or earth driving surface and has an average daily traffic of one hundred or fewer vehicles. A primitive road must be established by the County legislative authority.

**Private Road** – A road, though approved by the County, is not a county road.

**PT** – Point of Tangency

**Road, County** – See “County Road”

**Roadside Hazard** – A side slope, an object, water, or a drainage device adjacent to a road or street which, if impacted, would apply unacceptable impact forces on the vehicle occupants or place the occupants in a hazardous position. It may be either natural or man made.

**Segmental Retaining Walls (Modular retaining walls)** - Gravity retaining walls that rely primarily on their mass (weight) for stability. The system consists of concrete masonry units which are placed without the use of mortar (dry stacked), and which rely on a combination of mechanical interlock and mass to prevent overturning and sliding. The units may also be used in combination with horizontal layers of soil reinforcement

which extend into the backfill to increase the effective width and weight of the gravity mass.

**Shoulder** – That portion of the roadway contiguous with the traveled way for accommodating stopped vehicles, for emergency use, and for lateral support of base and surface courses.

**Superelevation** – A curve that has a banked slope.

**Tangent** – A straight line that touches a curve.

**Traveled Way** – That portion of the roadway intended for the movement of vehicles, exclusive of shoulders.

**Trip** – A one-directional movement that begins at the origin and ends at the destination. For example, a trip movement from a residence to a work place is a trip from home to work.

**Trip Distribution** – The process by which the movement of trips between zones is estimated. The data for each distribution may be measured or estimated by a growth factor process or by a synthetic model.

**Unopened Right-of-Way** – A county right-of-way that exists by dedication or deed, but for which no vehicular roadway has been constructed by the County or other parties.

**WSDOT** – Washington State Department of Transportation.

## ***Part 1 – General Information***

### **12.50.010 Purpose**

- A. These minimum standards for development provide requirements for road and bridge design, construction and reconstruction. In establishing the minimum standards for development, the County Engineer has sought to encourage standardization and Internationality of road design elements. Considerations include safety, convenience, aesthetics, proper drainage, and maintenance.
- B. The County’s permitting; certification or licensing activities require the adoption of Standards to guide individuals and entities in the administrative process of procuring the necessary County approvals. The County must also have flexibility to carry out its general duty to provide streets, roads and highways for the diverse and changing needs of the traveling public. Accordingly, these Standards are not intended to represent the legal standard by which the County’s duty to the traveling public is to be measured.
- C. The decision to use a particular road design element at a particular location should be made on the basis of an engineering analysis of the location. Thus, while this document provides minimum requirements for design, it is not a substitute for professional engineering judgment. It is the intent that the provisions of these Standards be International requirements for road and bridge design, but may not be appropriate for all locations and existing situations.
- D. These Standards cannot provide for all situations. It is intended to assist, but not substitute for, competent work by design professionals. It is expected that each professional bring to each project the best of their skills and abilities. These Standards are also not intended to unreasonably limit any innovative or creative effort which could result in the more effective and appropriate combination of design, cost savings, or both. Any proposed departure from these Standards will be judged on the likelihood that such a departure or variance will produce a compensating or comparable result, adequate in every way, for the road user and County resident.

### **12.50.020 Scope and Applicability**

- A. Except as exempted in Chapter 12.50.050, all requirements contained in these Standards, together with any and all amendments thereto, shall apply to all road, bridge, and other new construction and reconstruction of county and private roads in unincorporated Douglas County or as may be required as a condition of development approval as defined in Douglas County Code (DCC) Chapter 14.98 within Douglas County, and as far as practicable and feasible to the reconstruction of existing county and private roads in unincorporated Douglas County. These Standards shall also apply to all public and private accesses and driveways connecting to public roads; usage of unopened county rights-of-way; location and installation of new utilities;

and pedestrian, bicycle and equestrian facilities. In cases of any ambiguity or dispute over interpretation or application of the provisions of these Standards, the decision of the County Engineer shall be final subject to administrative appeal as set forth in DCC 14.12.010.

- B. These Standards apply to modifications of roadway features of existing facilities which are within the scope of reconstruction or capital improvement projects when so required by the County or to the extent they are expressly referred to in project plans and specifications.
- C. These Standards are applied as follows:
  - 1. Mandatory standards are those considered most essential to the achievement of overall design objectives. Mandatory standards use the word “shall”.
  - 2. Advisory standards allow some flexibility in application to accommodate design constraints or to be compatible with local conditions. Advisory standards use the word “should”.
  - 3. All standards other than the mandatory and advisory, indicated with the word “may”, are permissive with no requirement intended.
- D. If these Standards are silent regarding a specific issue regarding the planning, design or construction of a road or bridge then the AASHTO Geometric Design of Highways and Streets, WSDOT Standard Plans and Specifications, WSDOT Construction Manual, and the WSDOT City and County Design Standards as contained within the WSDOT Local Agency Guidelines shall provide guidance as to the requirements subject to approval by the County Engineer.
- E. For the purpose of these Standards, the defined “Administrator” shall be the County Engineer.

#### **12.50.030 Amendments**

- A. These Standards may be amended from time to time in accordance with Douglas County Code Chapter 14.32.
- B. All requests for amendments or revisions to these Standards from other County departments, other agencies or other outside parties shall be provided to the County Engineer for evaluation. Such requests shall be in writing and shall provide such supporting information as may be required by the County Engineer.

### **12.50.040 Definitions and Terms**

Unless otherwise defined or redefined within these Standards, all definitions and terms used in these standards are contained in Douglas County Code Chapter 14.98.

### **12.50.050 Exemptions**

These Standards shall not govern the following:

- A. Road and associated work done on roads that are under the authority, ownership or responsibility of other governmental agencies. In such cases, the standards of the other governmental agency shall apply.
- B. Road maintenance work within county road rights-of-way performed by county forces or by contract.
- C. Road maintenance work on private roads that does not affect the prior approved geometrics or adversely affect the safe passage of vehicles on the private road.
- D. Temporary road repairs made on an emergency basis.
- E. Resurfacing and restoration (“2-R”) projects.
- F. New road construction or reconstruction within urban growth boundaries where the County and a city or town have entered into an interlocal agreement to use the city’s or town’s road standards.

### **12.50.060 Interpretation, Enforcement and Appeals**

- A. Interpretation and enforcement of these Standards shall be the responsibility of the County Engineer or designated representative.
- B. Failure to comply with these Standards will be cause for withholding or withdrawing acceptance of plans or drawings, withholding of bond, final inspection approval or occupancy certificates and/or other penalties as provided for in DCC Chapter 14.92. For the purposes of DCC Chapter 14.92, the “director” shall mean the County Engineer or designated representative.
- C. All appeals of any decision by the County Engineer in his/her administration, interpretation or enforcement of these Standards shall be in writing and within fourteen (14) days of the decision. The written appeal, including the recommendations and analyses of the County Engineer, shall be made to the Douglas County Hearing Examiner in accordance with DCC 14.12.010.

### **12.50.070 Relationship to Other County Standards and Requirements**

Other Douglas County plans, standards and requirements for which these Standards are intended to be consistent with are:

- A. Douglas County Code, as amended, particularly Titles 12, 14, 15, 17, 18, 19 and 20
- B. Douglas County Comprehensive Plan, current edition
- C. Greater East Wenatchee Comprehensive Plan, current edition, and all other adopted community plans within Douglas County.
- D. Douglas County Non-Motorized Transportation Plan, when adopted

### **12.50.080 Reference Design Specifications**

Except where these Standards provide otherwise, design detail, construction materials and workmanship shall be in accordance with the following publications:

- A. WSDOT Standard Plans Specifications for Road, Bridge and Municipal Construction, current edition, henceforth referenced as the “WSDOT Standard Specifications” along with the WSDOT Design Manual, current edition
- B. WSDOT Standard Plans for Road and Bridge Construction, current edition, henceforth referenced as the “WSDOT Standard Plans”
- C. WSDOT Local Agency Guidelines, current edition, including the City and County Design Standards for the Construction of Urban and Rural Arterials and Collectors
- D. AASHTO “A Policy on Geometric Design of Highways and Streets”, fourth edition (2001), also known as the “Green Book”
- E. AASHTO “Guidelines for Geometric Design of Very Low-Volume Local Roads (ADT≤ 400), 2001
- F. USDOT “Manual on International Traffic Control Devices”, current edition as adopted, including amendments, by the Washington State Department of Transportation, henceforth referenced as the “MUTCD”
- G. ITE Trip Generation Manual, current edition
- H. HEC22, Urban Drainage Design Manual

- I. ADA guidelines for Public Right of Ways
- J. USDA Natural Resources Conservation Service Technical Release 55, “Urban Hydrology for Small Watersheds”
- K. Washington State Department of Ecology, “Stormwater Management Manual for Eastern Washington (when released and approved for use by DOE)
- L. WSDOT Construction Manual, current edition
- M. WSDOT Bridge Design Manual, current edition
- N. WSDOT Hydraulics Manual, current edition
- O. WSDOT Materials Manual, current edition
- P. WSDOT Roadside Manual, current edition
- Q. WSDOT Utilities Manual, current edition
- R. WSDOT Work Zone Traffic Control Manual, current edition
- S. WSDOT Highway Runoff Manual, current edition
- T. WSDOT Pedestrian Facilities Guidebook, current edition
- U. Department of Ecology, Criteria For Sewage Work Design, Pub # 98-37 WQ, 1998

#### **12.50.090 Project Acceptance**

- A. The County Engineer shall rely upon the certification and approval of the road and drainage plans and calculations by the applicant’s engineer for approval of the project. The County Engineer’s acceptance of the plans shall not relieve the applicant or the applicant’s Engineer from any liability related to portions of the design that are not in conformance with these Standards nor do not follow good engineering practice.
- B. Upon receipt of the project plans and calculations, the County Engineer will review the work of the applicant’s Engineer for accuracy and completeness. The plans and calculations will either be accepted by the County or returned for revisions. All revisions are subject to hourly review fees as set forth in the current fee schedule. Project acceptance occurs when the County Engineer signs the plans.

- C. The plans, reports, basin maps and calculations shall be signed, sealed and dated by the applicant's engineer. The cover sheet of the plan set and the cover sheet of all calculations shall bear the certification by the applicant's engineer that reads:

“The design improvements shown in this set of plans and calculations conform to the current edition of the Douglas County Road Standards. All design variances have been approved by the Douglas County Engineer. I approve these plans for construction.”

- D. The acceptance of plans shall be valid for a period of three (3) years from the date of approval by the County Engineer. Construction in accordance with the approved plans must be completed within this period. If not completed within this period, the plans shall be resubmitted to the County Engineer for review and any revisions or modifications necessary to meet the Standards in effect at the time of resubmittal shall be made. Re-submittal fees equal to new application fees shall be paid before the plans can be approved by the County.
- E. A Traffic Impact Analysis shall only be valid for a period of five (5) years from the date of approval of the development. If the project is not completed within this time period, the Traffic Impact Analysis shall be updated and resubmitted to the County Engineer for review and concurrence prior to project acceptance. Re-submittal fees equal to new application fees shall be paid before the updated analysis is approved by the County.
- F. Requests for modifications made during the construction of a project that are not in conflict with the preliminary plat approval conditions shall be approved by the County Engineer and County Fire Marshal, when applicable, prior to any changes being made in the field.
- G. Depending upon the nature of the modifications and in all cases where there is a conflict with the preliminary plat approval conditions, approval of the Douglas County Hearing Examiner will also be required as provided for in Title 14 of the Douglas County Code.

#### **12.50.100 Alternatives**

- A. These Standards represent reasonable approaches based on past experience in Douglas County and other jurisdictions. These Standards indicate the appropriate practice under most conditions.
- B. Engineering design is an endeavor that examines alternative solutions to real world situations and accordingly, these Standards are not provided to hamper the introduction of new ideas. It is fully expected that creative engineering will continue to take place. Situations will present themselves where alternatives may be preferred to allow conformance with existing conditions, to overcome adverse topography or to

allow for more affordable solutions without adversely effecting safety, maintainability or aesthetics. These Standards are intended to provide predictability yet still allow for the flexibility necessary for innovation.

- C. Alternatives to these Standards shall be proposed at the preapplication meeting and evaluated and accepted prior to the application submittal.
- D. The alternative request shall be in writing, submitted to the County Engineer, and address the following points:
  - 1. Specifically outline the reason for the alternative request.
  - 2. Specify the chapter and section for which the alternative is requested.
  - 3. Provide supporting evidence demonstrating that an alternative from these Standards is based on sound engineering judgment that the requirements for safety, function, appearance, fire protection and maintainability are fully met and complies with the Douglas County Comprehensive Plan and appropriate sub-area plan if applicable.
  - 4. The above information shall be used by the County Engineer in evaluating requests for the use of alternatives to these Standards. Alternative requests that conflict with the International Fire Code as adopted by Douglas County shall also require written concurrence from the County Fire Marshal.
  - 5. Any alternative proposal which achieves the standard but at an equal or greater value.

#### **12.50.110 Performance Assurance**

##### **A. Construction Performance**

- 1. In lieu of the completion of any required improvements prior to approval of a final plat, short plat, or other land-use action the County Engineer may accept a performance guarantee in an amount and with satisfactory surety and conditions providing for and securing to Douglas County the actual design, construction and installation of such improvements within a period specified by the County Engineer. The County Engineer will enforce the guarantee through appropriate legal and equitable remedies. If a surety bond is provided, the amount of the bond shall not be less than one hundred and twenty-five percent (125%) of the estimated design and construction cost as reviewed and concurred in by the County Engineer. See DCC 14.90 for specific instructions.
- 2. The amount of the performance guarantee may be reduced during construction, as determined by the County Engineer and based upon the amount of progress

payments. At no time will the performance guarantee amount be reduced to less than 30% of the original amount or \$5,000.00, which ever is greater.

3. Once a performance assurance is approved by the County, building permits or any additional permits required by the County may be issued prior to completion and approval of all road, drainage and utility construction. Building permits will only be issued if the roads are determined to be usable unless otherwise exempted by the Fire Marshal.

#### B. Maintenance Performance

1. The developer shall warrant all portions of construction work done in the right-of-way for a period of 18 months after completion or acceptance, which ever is later, against defective workmanship and materials. The developer shall keep the roads and public improvements in good order and repair during the 18 month period.
2. This warranty shall be secured with a form of collateral acceptable to the County Engineer in conformance with the requirements of Douglas County Code 14.90. The amount of this collateral shall be 15 percent of the original estimated or final design and construction cost as reviewed and concurred in by the County Engineer or \$5,000.00, which ever is greater.
3. This warranty collateral shall be submitted concurrently with a request for release of the construction performance guarantee and the two-year warranty period shall commence on the date of said release of the guarantee. The warranty collateral shall not be drawn upon. This warranty collateral will be held 18 months by Douglas County and will cover all improvements associated with the road system and its related drainage facilities.
4. During the course of the warranty period, periodic inspections will be conducted by the County Engineer or his/her representative. If deficiencies are observed, other than normal deterioration, they shall be brought to the attention of the developer for his/her action. At the end of the 18 month period, the County Engineer shall conduct a final inspection of the improvements and determine all work and an estimate of the cost necessary to restore the roadway, drainage facilities and any other improvements to their original design condition and provide said information to the developer. The developer shall have the option to perform all necessary restoration within a reasonable time as may be negotiated with the County Engineer. Should any or all of the restoration not be satisfactorily accomplished by the developer, the County Engineer will arrange for the accomplishment of the repairs. This restoration amount shall be deducted from the warranty collateral and the balance returned to the developer with an itemized list of all deductions; if the cost of the restoration work done by the County exceeds the amount of the warranty collateral, the developer shall be

billed by the County for the balance including an itemized statement of all work performed.

5. Maintenance guarantees will not be required when the required construction performance guarantee is \$1,000.00 or less.

#### **12.50.120 Violations and Penalties**

- A. Failure to comply with these Standards shall be cause for withholding or withdrawing approval of plans, forfeiture of financial security or non-acceptance of the work by the County.
- B. Violation of any provisions of these Standards by any person, firm or corporation shall be pursued and resolved in the same manner as any violation of Douglas County Code as provided for in Chapter 14.92.
- C. Notwithstanding the existence or use of any other remedy, the Director or County Engineer may seek legal or equitable relief to enjoin any acts or practices and abate any conditions that constitute or will constitute a violation of these Standards or other regulations herein adopted.

#### **12.50.130 Severability**

If any part of these Standards or its application to any person is, for any reason, declared invalid, illegal, or unconstitutional, in whole or in part by any court or agency of competent jurisdiction, said decision shall not affect the validity of the remaining portions thereof.

#### **12.50.140 Fees**

Fees shall be assessed in accordance with the current development fee schedule as approved by the Douglas County Board of County Commissioners.

#### **12.50.150 Transportation System and Frontage Improvements**

Frontage improvements are required for all improvement and development projects that have frontage on a public road that does not meet current standards. The transportation system and frontage improvements shall be in place, paid or be secured by means of an approved deferred improvement agreement no later than time of final plat approval or certificate of occupancy, whichever occurs first, for that development or phase. If the improvements are not listed on the County Transportation Improvement Plan, they shall be installed prior to final plat approval.

## A. Transportation Improvements – Off Site

Off-site transportation improvements such as road widening, additional right-of-way, paving, geometric improvements, additional lanes, traffic control devices, bridge and drainage structure modifications, pedestrian facilities, bike paths and intersection improvements away from the development shall be required where identified by a traffic impact analysis or otherwise be determined to be necessary as part of the development review process.

The Douglas County Department of Transportation and Land Services will also review the right-of-way status of abutting and adjoining county roads to determine if additional right-of-way is needed to meet the current road standards as set forth in these Standards.

All such required off-site improvements must be completed or other financing arrangements made as approved by the County prior to final development approval. Alternate financing methods such as use of Road Benefit Assessment Reimbursement Areas as set forth in DCC 12.45 may be used.

## B. Frontage Improvements – General Requirements

1. Frontage improvements may be required for all improvement and development projects that have frontage on a public road. Frontage improvements shall consist of, but not limited to, dedication of right-of-way, road widening, turn lanes, traffic signals, bus stop pads, bus shelter pads, passenger shelters, bus pullouts, pedestrian facilities, bike paths where designated in the current County Comprehensive Plan and safety and drainage improvements, including all tributary runoff.
2. Frontage improvements, including the dedication of right-of-way, shall be installed at the time of development unless otherwise approved by the County.
3. The developer shall coordinate the design and construction with the County and Link Transit when frontage improvements include bus stop pads, shelter pads and bus shelters. Prescription of a passenger shelter shall also incorporate the condition that the shelter meets Link Transit's standard passenger shelter specifications.

## C. Exceptions

The County Engineer may approve an alternative as set out in Chapter 12.50.150 D. to the installation of frontage improvements, not including dedication of right-of-way, if one or more of the following conditions apply:

1. The design grade and alignment of the abutting roads cannot be determined at the time of construction of the development.
2. The installation of frontage improvements required for the development would create or intensify a hazard to public safety.
3. The installation of frontage improvements required for the development could be more safely, efficiently, and effectively implemented if done concurrently with the installation of improvements required for other developments along the same road frontage.

#### D. Deferral of Improvements

Any deferred frontage improvement shall be secured for installation at a later date by an agreement and covenant between the County and the property owner whereby the property owner agrees to two methods of installation of the deferred frontage improvements. This agreement and covenant shall be executed before the issuance of any improvement and development permits. The County Engineer shall select which method to enforce against the property owner at the time when the deferred frontage improvements are required to be installed. Two methods the property owner shall agree to are:

##### 1. Commitment to Participate in an Improvement District

The property owner shall execute and record an agreement with the County and covenant running with the land that ensures the participation of the subject property owner in any local improvement district (RCW 35.43), road improvement district (RCW 36.88), or transportation benefit district (RCW 36.73) formed for the construction of such frontage improvements. Said document shall be in a form acceptable to the County Prosecuting Attorney's Office and shall be effective for a period not exceeding ten (10) years from the date of recording. This document shall bind the owner and its designees, heirs, transferees, donees, and/or successors in interest.

##### 2. Agreement to Participate in Improvement Project

The property owner shall execute and record an agreement with the County and covenant running with the land that ensures the participation of the subject property owner in an improvement project not supported by an improvement district that encompasses the said deferred frontage improvements by paying their share thereof. Such share shall be equal to the County's costs for installing the deferred frontage improvements. The County shall provide a non-binding total cost estimate to the property owner at the time the agreement is entered into including a disclaimer that the total cost of the project at the time of construction may vary due to inflation, changes in design standards or other governmental laws and regulations. A contract shall be developed at the time the improvement

project is developed outlining the level of participation by the subject property owner in said project and the manner in which payment is to be made; provided that the financial responsibility of the subject property owner shall not exceed the cost of said deferred frontage improvements at the time of the improvement project. Such an agreement and covenant shall bind the owner and its assignees, heirs, transferees, donees, and/or successors in interest. The agreement and covenant document shall be effective for a period of ten (10) years from the date of recording.

### 3. Voluntary Payments

See RCW 82.02.020.

#### **12.50.160 Withdrawal of Approval/Acceptance**

At the discretion of the County Engineer, errors and omissions in the approved/accepted plans or information used as a basis for such approvals/acceptances may constitute grounds for withdrawal of any approvals/acceptances and/or stoppage of any or all permitted work. It shall be the responsibility of the applicant to show cause why such work should continue, and make such changes in plans that may be required by the County before the plans are re-approved.

#### **12.50.170 Site Maintenance**

- A. The applicant shall schedule and control the work to comply with all applicable provisions of County development regulations and applicable state and federal laws and regulations to prevent any hazards to public safety, health and welfare.
- B. On existing roads, two way traffic and all existing lanes of traffic shall be maintained at all times unless detour and/or traffic control plans have been approved in advance by the County Engineer.
- C. Roads shall be kept free of dirt and debris.
- D. Pedestrian and bicycle facilities shall be kept free of obstructions.
- E. Pedestrian and vehicular access to occupied buildings shall be maintained except where written approval from the building owner has been obtained.
- F. Drainage facilities shall be maintained and fully functional and stormwater, erosion, and sedimentation control devices shall be maintained and fully functional.
- G. On-site grading shall be done in a manner to minimize off-site erosion and siltation in conformance with all statutory requirements, permits and approved plans.

### **12.50.180 Correspondence**

All correspondence, including letters, reports, and plans, shall be clearly labeled with the County project number as assigned by the Department. Submittals or correspondence without this identification number will not be accepted and will not be reviewed.

## ***Part 2 – County Road Classification***

### **12.51.010 Classification of Roads**

The applicable Standards shall be determined by the location (urban or rural areas), function (county or private), functional classification (arterial, collector or access) and projected traffic volumes and land use patterns. Terrain (flat, rolling, mountainous) will also enter into Standards related to design speed and maximum grade.

### **12.51.020 Classification Definitions**

#### **A. Location**

A primary determination of the applicable portions of these Standards that must be used is based on the location of the proposed road or street construction or improvement. In most cases, the following will govern whether rural, urban or city road standards will apply.

##### **1. Rural**

A rural location is defined as that area not within a federally designated urban or urbanized area or a designated Urban Growth Area as established by Douglas County under the Growth Management Act. Appropriate maps showing the boundaries are available from the Douglas County Department of Transportation and Land Services.

##### **2. Urban**

An urban location is defined as that area within a federally designated urban or urbanized area or a designated Urban Growth Area as established by Douglas County under the Growth Management Act. Appropriate maps showing the boundaries are available from the Douglas County Department of Transportation and Land Services.

##### **3. Other Urban Standards**

Other Urban Standards shall apply to all road and street construction in an area subject to an interlocal agreement between the City and the County to use that City's road and street standards.

## B. Function

### 1. County Roads

County roads are those that are continuously open to general public travel and have been accepted by the County into the County road system. Roads and streets that are dedicated to the public shall become county roads upon completion of the construction to County Standards, acceptance of the completed construction by the County Engineer, and approval of the final plat or other instrument as appropriate by the County. All others must be put on the county road system by means of the road establishment process as specified in RCW 36.81 and be constructed to County Standards for public roads.

### 2. Private Roads

Private roads are all roads not designated as public or County roads and not open to general public travel.

## C. Functional Classification - General

### 1. Rural Classifications

All county roads in rural areas are classified as Rural Local Access, Rural Collector (Major and Minor), Rural Minor Arterial or Rural Major Arterial. New roads and streets and any modifications to existing connector or frontage roads that may be required as a condition of development approval shall meet the minimum design requirements for rural roads as specified in these Standards. Different standards will apply depending upon the forecasted traffic volumes and functional classification. Appropriate maps showing the functional classifications are available from the Douglas County Department of Transportation and Land Services.

### 2. Urban Classification

All county roads in urban areas are classified as Urban Local Access, Urban Collector, Urban Minor Arterial or Urban Principal Arterial. New roads and streets and any modifications to existing connector or frontage roads that may be required as a condition of development approval shall meet the minimum design requirements for urban roads as specified in these Standards, provided however, local access roads outside of Urban Growth Areas yet within a Federal Urbanized Area may use a rural standard. Different standards will apply depending upon the functional classification. Appropriate maps showing the functional classifications are available from the Douglas County Department of Transportation and Land Services.

#### D. Functional Classification – Descriptions

1. Principal Arterial (Urban & Rural) – Principal arterials permit traffic flow through and between cities and towns and between major elements of the urban areas. They are of great importance in the regional transportation system as they interconnect major traffic generators, such as central business districts and regional shopping centers, to other major activity centers and carry a high proportion of the total area travel on a minimum of roadway mileage. Principal arterials frequently carry important intra-urban as well as inter-city bus routes.

Many principal arterials are fully or partially access controlled facilities emphasizing the through movement of traffic. Within the category are (1) interstates (2) other freeways and expressways and (3) other principal arterials. Spacing of principal arterials may vary from less than one mile in highly developed central business areas to five miles or more in sparsely developed urban fringes and rural areas. Principal arterials generally comprise 5-10 percent of the urban system and 2-4 percent of the rural road miles.

2. Minor Arterial (Urban & Rural) – Minor arterials collect and distribute traffic from principal arterials to lesser-classified streets, or allow for traffic to directly access their destination. In urban areas, they serve secondary traffic generators such as community business centers, neighborhood shopping centers, multiple residence areas, and traffic from neighborhood to neighborhood within a community. Urban bus routes generally follow these facilities. Access to land use activities is generally prohibited. Such facilities are usually spaced under two miles apart in urban fringes and in core areas can be spaced 1/8 to 1/2 mile apart. In sparsely populated areas of our rural counties, minor arterials may be widely disbursed or non-existent. Rural minor arterials, in conjunction with rural principal arterials, are spaced at such intervals that all developed areas of the state are within a reasonable distance of an arterial highway. Rural minor arterials are expected to provide for relatively high overall travel speeds with minimal interference to through movement. Rural minor arterials generally comprise 4-8 percent of the system; whereas, in urban areas they generally comprise 10-15 percent.
3. Collectors (Urban) – Urban collectors provide for land access and traffic circulation within residential neighborhoods and commercial and industrial areas. They distribute traffic movements from such areas to the arterial system. Half-mile spacing is common in more developed areas. Collectors do not handle long through trips and are not continuous for any great length. They generally account for 5-10 percent of the total street system.

4. Collectors (Rural) – Rural collector roads are classified as major collectors and minor collectors. These routes generally serve travel of primarily intra-county rather than statewide importance and constitute those routes on which (regardless of traffic volume) predominant travel distances are shorter than on arterial routes. Consequently, more moderate speeds may be typical. Rural collectors, both major and minor, generally constitute 20-25 percent of the rural road miles.

Rural major collectors provide service to any county seat not on an arterial route; to larger towns not directly served by an arterial; and to other traffic generators of equivalent intra-county importance, such as consolidated schools, shipping points, parks, important agricultural areas, etc. Major collectors link these places with nearby larger towns or cities or with routes of higher classification and serve the more important intra-county travel corridors.

Rural minor collectors should be spaced at intervals, consistent with population density, to collect traffic from local roads and bring all developed areas within a reasonable distance of a collector road. Furthermore, minor collectors provide service to the remaining smaller communities and also link the locally important traffic generators with their rural hinterland.

5. Local Roads and Streets (Rural & Urban) – All public roads and streets, not otherwise classified as an arterial or collector, comprise the local access system. These roadways primarily serve local needs for access to adjacent lands, travel over relatively short distances, and connections to collectors or other higher systems. Local urban streets offer the lowest level of mobility and usually contain no bus routes. Service to through traffic movement is deliberately discouraged. Local streets usually account for 65-80 percent of the urban system. In rural areas, the local roads generally comprise 65-75 percent of the road miles.

#### E. Terrain

Terrain is a basis for further classification of geometric requirements.

1. Flat terrain is that condition where roadway sight distances, as governed by both horizontal and vertical restrictions, are generally long or could be made to be so without construction difficulty or major expense. The slope of the existing terrain is from 0% to and including 5%.
2. Rolling terrain is that condition where the natural slopes rise above and fall below the roadway grade line consistently. Normal roadway alignment is restricted by occasional steep slopes. The slope of the existing terrain is from 5% to and including 15%.

3. Mountainous terrain is that condition where longitudinal and transverse changes in the elevation of the ground with respect to a roadway are abrupt and where the roadbed is obtained by frequent benching or side hill excavation. The slope of the existing terrain exceeds 15%.

Terrain classification pertains to the general character of the specific route corridor. Roads in valleys or passes of mountainous areas that have all the characteristics of roads traversing flat or rolling terrain should be classified as flat or rolling. In rolling terrain, trucks reduce their speeds below those of passenger cars on some sections of roadway. Mountainous terrain is responsible for some truck operation at crawl speeds. In cases where the terrain classification is in question, the County Engineer shall make the final decision.

## ***Part 3 – Design Criteria for Roads and Streets***

### **12.52.010 Scope**

The purpose of this chapter is to present criteria for the design of roads and streets. It is to be used by developers and their engineers in the design of both public and private roads and streets for which approval by the County Engineer is required.

### **12.52.020 General Requirements**

#### **A. Minimum Standards**

The provisions stipulated in this section are required minimum standards and shall be considered applicable to all parts of these specifications including any supplements and revisions. All construction within the public right-of-way shall be designed by or under the direct supervision of a registered professional engineer licensed to practice in the State of Washington. All drawings and support data submitted to the County for approval must bear his/her seal. The signature of the registered professional engineer will only be required on the approved final plans.

The design criteria, as presented, are intended to aid in preparation of plans and specifications and include minimum standards where applicable. These design criteria are considered minimum and a complete design will usually require more than is presented in this document. As with any design criteria, occasions may arise where the minimum standards are either inappropriate or cannot be justified economically and an equal but alternative solution may be proposed. A written request for each alternative shall be directed to the County Engineer and shall conform to criteria in DCC 12.50.100 “Alternatives”.

#### **B. Application to Private Roads**

Although community road requirements are usually best served by public roads owned and maintained by the County, private roads may be appropriate for some local access roads for either residential or commercial/industrial property. These standards apply to private roads as part of the County’s responsibility to insure adequate access for normal and emergency vehicle use to individual parcels throughout the County.

Private roads are permitted only when all of the following conditions are met:

1. Permanently established by tract or easement providing legal access to each affected lot, dwelling unit, or business and sufficient to accommodate required improvements, to include provision for future use by adjacent property owners when applicable.
2. Constructed to Douglas County Road Standards as set forth herein.

3. Accessible at all times for emergency and public service vehicle use.
4. Not obstructing, or part of, the present or future public neighborhood circulation or arterial plan developed in processes such as the Douglas County Comprehensive Plan, applicable community plan, or Capital Improvement Plan.
5. Designed for an average daily traffic count (AADT) of 160 or less vehicles per day utilizing current ITE guidelines. New private roads directly accessing a county road that will generate more than 160 AADT will be permitted only by approval by the County hearing examiner and will be required to meet the appropriate county road rural or urban Road Standards contained herein (see Figures 3-2 through 3-8). There is no maximum AADT provision if a new development is served by an extension of, or spur off, an existing private road, however, should such existing private road be less than the Standards considering the current and proposed AADT, the new development may be denied unless a lower level of improvement has been approved by the County hearing examiner upon recommendation by the County Engineer or the applicant assumes responsibility for bringing the existing private road serving the new development up to these Standards.
6. Maintained in accordance with these standards by a capable and legally responsible owner, homeowner's association or other legal entity made up of all benefited property owners. A written road maintenance agreement addressing the rights and responsibilities of all benefited property owners shall be approved by the Department prior to final approval of the land development. Said road maintenance agreement shall be recorded with the County and shall become a covenant with the effected properties. The term "benefited property owners" shall include the owners of record of all properties with frontage, including access rights, on the private road or otherwise have legal access, whether constructed or not, to the private road.
7. Clearly described as a private road not maintained by the County on the face of the plat, short plat or other development authorization.
8. Clearly signed at the road location as a private road, the maintenance of which the County is not responsible.

### **12.52.030 General Design Principles for New Roads**

#### **A. Road Network Circulation**

The importance of good road network circulation for the health, welfare and safety of the public cannot be overemphasized. Poor circulation adds unnecessary miles to pedestrian and trail systems, school bus routes, mail delivery and other service deliveries, utility services and most importantly, emergency services such as police

and fire. Through good road network circulation, the public will have better emergency access and police and fire safety will be enhanced.

1. Plans will be reviewed for the provision of the best possible road and pedestrian network circulation and for conformance with any adopted comprehensive plan. The road alignment may necessitate re-alignment in order to foster the long-range transportation objectives of the County. This includes greater scrutiny to provide continuity of pedestrian and other trail systems related to the proposed road network. The inclusion of permanent cul-de-sacs is strongly discouraged as they inhibit road and pedestrian network circulation (see 12.52.040 L for specific requirements) and are not consistent with the County Comprehensive Plan.
2. To facilitate the best possible road and pedestrian network circulation, if it is determined by the County Engineer, after making an individualized determination, that the layout of roads are to provide for the continuation of existing roads in adjoining subdivisions, then the roads shall be constructed prior to final plat approval. When adjoining property is not subdivided, the County Engineer shall determine whether roads in the proposed plat are to provide access to such unplatted property. The location for access to unplatted property shall be placed such that the objectives in these Standards can be achieved. Reserve easement strips may be required to prevent unauthorized access until such time as the connecting roads are constructed.
3. If the roads are to remain private, the above still applies except a separate tract or easement will be shown on the final plat map and they will not be dedicated to the public. Specific information in the recorded covenants regarding the use of this easement will be required.
4. Unless otherwise approved, all lots within major subdivisions shall be accessed by means of an internal road network. This network may be public or private but not a mixture of both. Access easements or multi-dwelling driveways in lieu of public or private roads shall not be permitted.

## B. On-Site Principles

An integral part of an overall traffic study relates to basic site planning principles. An integrated on-site roadway system should deliver vehicles from the external roadway system in a manner easily understood by typical drivers and that maximizes efficiency, accommodates anticipated traffic patterns and ensures public safety.

### 1. Alignment

Connecting street centerlines deflecting from each other more than ten degrees shall be connected by a curve the radius of which shall be approved by the

County Engineer. Street intersections shall be as nearly at right angles as is practicable, and street jogs having offsets of less than one hundred twenty five (125) feet shall be avoided.

## 2. Internal Vehicular Circulation

Internal circulation is the means by which vehicular traffic is delivered between entry points and parking areas, pick-up/drop-off points, and service areas, and should be planned to accommodate appropriate future traffic volumes.

## 3. Subdivision Boundary Streets

A street lying along the boundary of a subdivision may be dedicated with less than the width required by these standards if it is practicable to require the dedication of the remaining portion of such width when the adjoining property is subdivided. In such case there is required a reserve easement strip one foot wide along such street for the purpose of withholding access to the unsubdivided property from such street until a street is constructed to the full width required. The procedure shall also apply in the case of any street that dead-ends at the boundary of a subdivision.

## 4. Access points

Roads and lots shall be laid out to provide individual lot access onto an internal roadway system, hence via the internal roadway system to the existing public road system. Direct access to a perimeter road shall normally be denied except for direct access onto a designated local access road.

## 5. Parking

Parking shall be provided to meet site-generated demands and be consistent with Title 20 of the Douglas County Code and other planning department policies.

## 6. Vehicular Queuing and Storage

- a. Access drives should provide adequate vehicular exit queuing.
- b. Parking areas and access points of small developments should be designed so vehicles waiting to exit are aligned perpendicular to the off-site roadway system.

- c. Queuing areas of large developments should be sufficient so vehicles queued at exits do not block internal circulation. Exits shall be signalized if warranted by the MUTCD at build out.
- d. Documentation shall be provided to verify queue lengths for signalized intersections, on-site queuing reservoirs, and off-site left and right-turn lanes.

## 7. Building Service Drives

Building service drives are roadways adjacent to a building and its entrances, and should be designed with sufficient width to serve as one or all of the following:

- a. Fire and/or emergency vehicle access
- b. Pedestrian pick-up/drop-off points

Pedestrian crossings and pick-up/drop-off points should be signed and striped to identify the vehicular/pedestrian conflict.

- c. Internal circulation
- d. Recirculation in parking areas

Recirculation aisles shall have sufficient turning radii, clearances, sight distances and signing.

- e. Transit passenger pick-up/drop off areas.

## 8. Pedestrian, Bus, Bicycle, and Disabled Access Facilities

The overall site plans must consider pedestrians, bus, bicycle, and disabled access facilities.

- a. Pedestrian Facilities

Pedestrian connections between public transportation facilities and site buildings shall be integrated into the overall project design. Pedestrian facilities shall be designed to reduce the motor vehicle use for trips within the development and between nearby developments.

b. Transit Facilities

Appropriate public transportation facilities, such as passenger shelters, ride sharing areas and bus staging areas shall be accommodated adjacent to service drive and entrance areas; at key locations along circulation drives; and at major pedestrian focal points along the external roadway system as determined the County and LINK Transit.

c. Bicycle Facilities

Facilities for parking bicycles should be provided where bicycle use is expected. Refer DCC 18.16.

d. Disabled Access Facilities

Access for disabled persons shall be provided in accordance with federal, state and County requirements.

9. Service and Delivery Vehicles

Service and delivery vehicles require separate criteria for movement to and from the site:

- a. Vehicle turning paths shall be sufficient to accommodate the largest vehicles anticipated, a minimum single unit truck (SU).
- b. Service vehicle access points shall have turning paths sufficient to allow service vehicles to enter and exit the site without encroaching upon opposing lanes or curbed areas.
- c. External and internal roads shall have sufficient separation for large vehicles to be queued on entry or exit without blocking access to parking spaces or internal roadways.

C. Fitting the Road into the Environment

When land development requires the construction of new roads, there are opportunities to 'fit' the road into the existing landscape and environment in ways that are more pleasing to the eye than just simple straight lines.

The principles set forth in this section stress the importance of protection, conserving, and enhancing the scenic qualities of a county road. They primarily address rural situations but can apply to urban streets in many cases, especially in major subdivisions with an extensive new road system. They are also consistent with good engineering and the necessity to provide a roadway which is safe to travel and

economical to construct and maintain. Unless conditioned by 'shall', these principles are not regulatory but are advisory only to provide guidance to developers.

## 1. Relating Alignment to the Landscape

A unique visual quality of most county roads is the harmonious relationship their alignments have with the landscape. Increased volumes of traffic, poor sight distance, or other operational conditions may often necessitate modification of an existing alignment. If such a change is necessary, the roadway geometry usually must become more precise and directional. However, a new alignment should not be considered a straight line connecting two points. Rather, it should seek the same qualities of existing alignments by reinforcing and revealing the features of the landscape. The following guidelines will be useful for relating new alignments with the landscape:

- a. Choose an alignment that blends with the terrain and adjusts to important scenic features.
- b. In most instances, the appropriate alignment will be characterized by curves that continually adjust to the rolling topography of natural landform. A curvilinear alignment is visually and functionally preferable to long tangents that cut through hillsides, leaving steep unsightly and unstable embankments.
- c. Where the land is level, or a strong lineal direction is created by landscape elements, such as a long row of trees or the patterns of fields, the use of a long tangent may be justified. When using a long tangent, try to direct it toward a natural or man-made focal point.
- d. When climbing a hillside, the roadway should bend to the crest, traversing the contours, rather than climbing it straight on. However, care must be taken to avoid hiding a curve or driveway just beyond the brow of a hill.
- e. When crossing a ridge, pick a saddle or low area in the top to locate the roadway.
- f. Natural and man-made features provide variety and contrast which maintain the traveler's interest. Whenever possible, alignments should be located to bring the more interesting features into view.
- g. Near the edges of surface water, woods, or a break in topography, use alignments that echo or emphasize the shape of the edges. However, avoid moving roadways close to the waters edge as it destroys habitat.

- h. When approaching important features, it is preferable to allow a distant view of the object, curve the alignment away, and then bring it close for a contrasting view.

A road which blends with the form and pattern of the landscape is also desirable from the standpoint of construction and maintenance. Some of the advantages to be gained are reduction of cut and fill quantities, more efficient utilization of natural drainage, and better control of roadside erosion because natural vegetation is preserved.

## 2. Combining Horizontal and Vertical Alignment

The combination of horizontal and vertical alignments closely influences the appearance and safety of a roadway. When alignments are properly coordinated, a roadway will be visually pleasing and safer to travel. Alignment coordination primarily applies to major roadways, but the basic principles should also be recognized as important considerations when altering minor roadways. Set forth below is a partial list of suggestions to guide the combination of horizontal and vertical alignments:

- a. Consistency in the scale of horizontal and vertical elements should be maintained whenever possible. Small dips and humps should be avoided in what is actually a uniform grade, and “kinks” should be avoided in what is actually a long curve.
- b. The beginning and ending of horizontal and vertical alignments should not occur in the same location. The beginning of a horizontal curve should generally occur before beginning a vertical curve and be somewhat longer in length. This provides a gradual transition between the alignments and prevents one from accentuating the other.
- c. The beginning of a horizontal curve should not coincide with the top of a hill. This situation is visually deceptive and hazardous, as the quick change in horizontal alignment cannot be seen by the driver.
- d. Avoid dips in vertical alignment before beginning a horizontal curve. This will prevent the roadway from appearing disjointed.
- e. Avoid “broken back” curves (two horizontal curves in the same direction with a short tangent in-between), compound curves or reverse curves except for local access roads with a design speed of 25 MPH.
- f. When an extremely long grade is necessary, it may be better to adjust the vertical alignment so the grade is steeper near the bottom of the hill and

gradually lessens as it approaches the crest of the hill. Another alternative is to create an alignment with intervals of lesser grades

- g. Sight distance requirements vary with the anticipated speed of vehicles. Adequate sight distance must be provided. This should be checked at all horizontal curves and crest vertical curves.

### 3. Cross Section

The small scale of cross-section elements is an important characteristic adding to the scenic quality of a county road. This aspect is most apparent in the width of the traveling surface, its adjacent shoulders, and the close proximity of the roadside. Where traffic volumes are low, speeds are slow, and meeting and passing of vehicles is infrequent, a narrow cross section may be appropriate.

Modifications which require widening of the roadway will alter the existing scale of the county road and consequently its visual impact on the motorist and adjacent properties. The following considerations should guide the determination of an appropriate cross-section:

- a. Appropriate widths should be determined by the function the road serves as part of the county road system, operational requirements for safe vehicular movement, and the characteristics of topography and other physical features (check results of planning considerations). In most cases, the minimum cross section, based on rural/urban location, functional class and traffic volume is shown in Figures 3-1 through 3-8 at the end of this part.
- b. Consider all elements of the cross-section (traveling surface, shoulders, ditches, proper grading to stabilize cut and fill slopes, slope rounding, etc.).

### 4. Roadside Slopes

Proper molding of roadside slopes is essential during the grading operation. Slopes which do provide a smooth visual transition from the roadway to existing land forms have a pleasing appearance. Slopes shaped in this manner are also required for effective erosion control, adequate drainage, and reduced maintenance. Some general guidelines to follow when grading the roadside are set forth below:

- a. Where the topography is flat to rolling and the landscape is open, slopes which are flattened and well-rounded are appropriate. Flattening of slopes to 4:1 (4 horizontal to 1 vertical) should be carried out.

- b. Where the topography is steep, uneven, and wooded, roadside slopes with grades of 2:1 or 3:1 should be favored to save roadside vegetation. However, check to make sure the slope is flat enough to be stable.
- c. Vary the steepness of roadside slopes to save vegetation and other landscape features.
- d. On areas of extreme cut, which may require easements or more right-of-way, the use of small benches, stepped down a steep slope, will slow water runoff and provide excellent locations where vegetation can quickly take hold. It is important to maintain a slight downhill pitch on these benches to provide adequate drainage.
- e. On fill slopes of extreme length, larger benches can be formed to fulfill the same functions as above.
- f. All slopes should be well-rounded to form a smooth transition from the shoulder edge to the existing grades. Deep ditches with well-defined bottoms are required where drainage or soils are poor. Rounded or shallow ditches are acceptable when there is little drainage and the soil is free draining.
- g. All slopes should be warped by flattening the ends of cut and fill areas. This will avoid sharp breaks between new and existing grades and result in natural looking slopes that will more effectively support vegetation.
- h. When grading the roadway, avoid disturbing important roadside vegetation and the creation of deep cuts that expose tree roots and leave steep banks that are susceptible to erosion and difficult to maintain.

## 5. Ditches

Ditches provide an important function in sustaining quality roads by providing adequate storm and subgrade groundwater drainage. However, excessively deep or wide ditches can severely impact vegetation, the rural feel of a road or safety. Several issues to consider when selecting a ditch section follows:

- a. Slopes from the roadway to the ditch bottom shall be at least 4:1 or greater. The shallower pitches will allow for some vehicle recovery and less potential of a vehicle overturning on higher speed roadways.
- b. Ditches must be deeper than the subgrade to allow drainage of roadway base and surfacing courses.

- c. Where ditch construction may impact significant roadside features, short sections of culvert, curtain drains or shallow or no ditches at all should be considered, subject to approval by the County Engineer.
- d. Ditches must be constructed to adequately carry the anticipated water flow.
- e. Biofiltration (or water quality) swales and grass buffer strips are encouraged at all locations where the road gradient makes them a practical alternative to regular roadway ditches.

**12.52.040 Design Requirements – New and Reconstructed Roads**

The following minimum design standards shall apply to all new and reconstructed roadway. Exhibits showing the basic cross-section requirements for the various road classifications are shown in Figures 3-1 through 3-8 at the end of this Part.

**A. Road Base and Surfacing Requirements**

The following road surfacing requirements shall apply to all new and reconstructed roads.

**1. Surfacing**

The minimum road surfacing requirements for various traffic volumes and locations are shown in Table 3-1:

**Table 3-1 Road Surfacing Requirements**

<b>Location</b>	<b>Figure</b>	<b>Traffic Volume (AADT)</b>	<b>Road Surface Type</b>
Rural – Private	3-1, 3-2, 3-3	Up to 160 Over 160	Crushed Surf. Top Course BST Class A
Rural – Public	3-2, 3-3, 3-4, 3-5, 3-6,	Up to 400 Over 400	ACP <sup>1</sup> ACP
Urban – Private	3-7, 3-8	All	ACP or PCC
Urban – Public	3-7, 3-8	All	ACP or PCC

<sup>1</sup> BST Class A will be allowed for local access roads up to 400 AADT. All other classes require ACP

## 2. Structural Sections – Public Roads

### a. Design Procedure

A roadway section structural design procedure shall be performed for all new and reconstructed public roads. The design life for all roads shall be 20 years with a growth factor as determined by the County Engineer. The design procedure shall be approved by the County Engineer and shall consider the following design elements:

- (1). Design Load – HS 20-44
- (2). Total Design Life Traffic Loading – An estimate of the number and types of loadings the roadway will carry for the design life. This estimate of loading shall be determined using a procedure accepted by the County Engineer and be expressed in 18-kip Equivalent Single Axle Loads (ESAL's).
- (3). Subgrade Support – One or more representative values for the stiffness of the native material on which the road will be built. These values shall be established by a procedure accepted by the County Engineer and be expressed as resilient modulus.
- (4). Analysis – A procedure for establishing the roadway structural section for a given traffic loading and resilient modulus. This procedure shall be approved by the County Engineer.

### b. Construction Requirements

All structural sections including surfacing shall use materials meeting the specifications of and be constructed in accordance with the WSDOT Standard Specifications. Minimum compaction requirements shall be 92 percent for asphalt concrete pavement and 95 percent for crushed surfacing and base courses. See Chapter 12.56 for details and further guidance.

## 3. Structural Section – Private Roads

Private roads with a projected AADT under 160 do not require roadway section structural design; however the requirement for minimum thickness will apply. Private roads with a projected AADT under 160 that are constructed without a roadway structural design will not be eligible for future inclusion into the county road system without further structural analysis as may be directed by the County Engineer.

4. Minimum Thickness

- a. In all cases, the minimum roadway structural section shall be as shown on Figures 3-1 through 3-8.
- b. Many areas of Douglas County have soils excessively susceptible to frost heave. The applicant or applicant’s engineer shall consult with the County Engineer’s office as to those locations with known frost heave problems or with soils likely to generate excessive frost heave. These locations may require additional base thickness.

B. Design Speed

Design speeds for urban and rural roads and streets shall be as shown in Table 3-2:

**Table 3-2 Design Speeds**

Location/AADT	Terrain – Design Speed in MPH			
	Figure	Flat	Rolling	Mount.
Urban – Private <sup>1</sup>	3-7	25	25	20
Urban – Local Access	3-7	25	25	25
Urban – Collector	3-8	35	30	25
Urban - Arterial	3-8	45	45	45
Rural – Private (400 or less) <sup>2</sup>	3-1	40	30	20
Rural – Local Access 400 and less	3-2	50	40	25
Rural – Local Access over 400	3-3	50	40	30
Rural – Collectors 400 and less	3-4	50	40	30
Rural – Collector 401 to 2000	3-5	60	50	40
Rural – Collector & Arterial over 2000	3-6	60	50	40

<sup>1</sup> Private urban shall meet the Urban Local Access standard

<sup>2</sup> Private rural over 400 AADT shall meet the Rural Local Access standard

See 12.51.020 E for terrain definitions.

C. Right of Way

The basic minimum rights-of-way for all roads are shown in Figures 3-1 through 3-8. Additional right-of-way shall be required to accommodate other road features such as additional lanes, planter strips and transit stops. Construction and maintenance easements may be allowed for cut and fill slopes.

D. Lane, Shoulder and Roadway Width

Basic lane, shoulder and total roadway and surfacing minimum width requirements are shown in Figures 3-1 through 3-8. Minimum widths are based on a combination of roadway classification and traffic volume (AADT).

Urban roadway sections (Figures 3-7 and 3-8) assume parking on both sides. Rural and private roadway sections do not include additional width for parking; when parking space is required, additional width will be required. Additional width may also be required to accommodate removal and storage of snow.

Where truck traffic exceeds 15 percent of the projected AADT, 12-foot lanes will be required for all rural roadway classifications.

#### E. Ditch Slopes

The slope from edge of shoulder to bottom of ditch shall be 4:1 for all ditch roadway sections; except that 3:1 will be allowed for rural private roads under 160 AADT. See Chapter 12.57.020 for cut and fill slope requirements.

#### F. Sight Distance

All new roads and streets shall be designed to achieve the following sight distances:

1. Stopping Sight Distance – 2001 AASHTO Green Book, Exhibit 3-1, page 112.
2. Passing Sight Distance – 2001 AASHTO Green Book, Exhibit 3-7, page 124.
3. Intersection Sight Distance – WSDOT “Design Manual M22-10”, Chapter 910.10, “Intersections at Grade – Sight Distance at Intersections”.

#### G. Superelevation

Superelevation shall normally be applied to all new or reconstructed roads and streets. The maximum superelevation for roads with a design speed of 35 MPH or greater shall not exceed 6 percent and for roads with a design speed under 35 MPH shall not exceed 4%, provided however, that the combination of superelevation and road gradient shall not exceed 12% at any point on the roadway surface

#### H. Horizontal Alignment (Curvature)

The minimum curve radius for all new or reconstructed rural highways and higher speed urban roads shall not be less than the ‘rounded radius’ values in the AASHTO Green Book, Exhibit 3-14, page 145 using a maximum superelevation rate of 6% for design speeds of 35 MPH or greater and a maximum superelevation rate of 4% for design speeds under 35 MPH.

Low speed urban streets (design speed of 30 MPH or less) may use the minimum curve radii as set forth in Exhibit 3-41, page 197 of the AASHTO Green Book based on a maximum superelevation rate of 4%. Lesser curve radii may be used only with the permission of the County Engineer.

## I. Vertical Alignment

### 1. Maximum Grades

The maximum and minimum grades for each roadway classification are shown in Figures 3-1 through 3-8.

### 2. Vertical curves

Sag vertical curves shall be designed in accordance with the 2001 AASHTO Green Book, Exhibit 3-78, page 278, "Design Controls for Sag Vertical Curves – Open Road Conditions, and Exhibit 3-79, page 280, "Design Controls for Sag Vertical Curves"

Crest vertical curves shall be designed in accordance with the 2001 AASHTO Green Book, Exhibit 3-75, page 273, "Design Controls for Crest Vertical Curves – Open Road Conditions", Exhibit 3-76, page 274, "Design Controls for Stopping Sight Distance and for Crest Vertical Curves", and Exhibit 3-77, Page 276, "Design Controls for Crest Vertical Curves Based on Passing Sight Distance".

## J. Vertical Clearance

The minimum vertical clearance for all roadways under structures such as overpasses shall be sixteen and one half (16-1/2) feet.

## K. Design Vehicle

The physical characteristics of vehicles and the proportions of various sized vehicles using the road system are positive controls in geometric design. For road design purposes, three general classes of vehicles have been selected – passenger cars, trucks and buses/recreational vehicles. The passenger car class includes compacts and subcompacts plus all light vehicles and light delivery trucks (vans and pickups). The truck class includes single-unit trucks, truck tractor-semitrailer combinations, and trucks or truck tractors with semitrailers in combination with full trailers. Buses/recreational vehicles include single-unit buses, articulated buses, school buses, motor homes, and passenger cars or motor homes pulling trailers or boats. In addition, where provision is made for bicycles on a road, the bicycle should also be considered a design vehicle.

The dimensions for the fifteen design vehicles representing vehicles within these general classes are provided in the 2001 AASHTO Green Book, Chapter 2. In the design of any road facility, the largest design vehicle likely to use that facility with considerable frequency or a design vehicle with special characteristics that must be taken into account in dimensioning the facility is used to determine the design of such critical features as radii at intersections and radii of turning roadways.

Unless unusual sized vehicles must be accommodated, the typical design vehicle used for design of roads shall be of the following classes:

**Table 3- 3 Design Vehicles**

<b>Roadway Class</b>	<b>Design Vehicles <sup>1</sup></b>
Rural and Urban Arterials and Rural Collectors	Large School Bus (S-BUS40)/Intermediate Semitrailer (WB-50)
Urban Collectors	Large School Bus (S-BUS40)/Single Unit Truck (SU)
Rural and Urban Local Access	Large School Bus (S-BUS40)/Single Unit Truck (SU)
Private	Single Unit Truck (SU)/Passenger Car (P)

<sup>1</sup> Refer AASHTO Green Book, Chapter 2 for specific design data

L. Cul-de-sacs and dead end roads

Permanent cul-de-sacs and dead end roads are not normally permitted within new developments. Permanent cul-de-sacs will only be permitted where the applicant can (a) demonstrate that his/her design does provide an acceptable level of network circulation considering the terrain and adjacent existing roadway network, and (b) demonstrate that the prohibition of cul-de-sacs will place an unreasonable economic impact on the applicant.

Where permitted, the following requirements shall apply:

1. Permanent road ends of 150 feet or less in length (measured from the edge of traveled way of the intersecting road to the end of the road) shall have a minimum right-of-way and roadway section as specified in Figures 3-1 through 3-8 and do require an access easement turnaround.
2. Permanent road ends between 150 and 600 (measured from the edge of traveled way of the intersecting road to the beginning of the cul-de-sac) shall have a minimum right-of-way and roadway section as specified in Figures 3-1 through 3-8 and be provided with a cul-de-sac as shown in Figure 3-9.
3. Permanent road ends in excess of 600 feet are discouraged but may be allowed in cases where lots are large and/or difficult terrain exists, provided, the number of

single-family lots served by the road does not exceed 20 or the projected AADT generated from the properties served by the road does not exceed 200. The roadway shall have a minimum right-of-way and roadway section as specified in Figures 3-1 through 3-8 and be provided with a cul-de-sac as shown in Figure 3-9.

4. The maximum gradient in any direction and at any point within a cul-de-sac shall not exceed 4 percent.

#### M. Intersections

All intersections shall be designed in accordance with Chapter 9, "Intersections" in the 2001 AASHTO Green Book or Chapter 910, "Intersections at Grade" in the current edition of the WSDOT "Design Manual M22-01". All intersections with a state highway shall require approval from the WSDOT.

Corner lots, located at road intersections, shall be rounded with a minimum twenty (20) foot radius adjacent to roads with sixty (60) foot or more rights of way and twenty five (25) foot radius adjacent to roads with less than sixty (60) foot rights of ways.

#### N. Boundary (half) roads

Boundary or half roads may be permitted to be dedicated with less than the width required by these Standards if the County determines that it practicable to require the remaining portion of such width when the adjoining property is subdivided. Boundary or half roads with widths less than those required by these Standards are not allowed adjacent to public parkland or properties owned by public school districts.

#### O. Transit Stops and Pull-Outs

Property owners and/or developers of proposed developments or other types of land uses located within the LINK transit service area and which generate two hundred average daily or twenty peak hour vehicle trips, as determined by the County Engineer, shall negotiate with the public transit authority. The improvements that would enhance the area for public transit. Improvements may include bus shelters, pullouts, transit stops, and/or other necessary facilities to offset transportation system impacts of the development and shall be analyzed as part of a traffic impact analysis prepared in accordance with DCC Chapter 20.30.

#### P. Railroad Grade Crossings

All proposed railroad crossings on public right-of-way must be submitted to the County Engineer prior to being processed through the Railroad and the Utilities and

Transportation Commission for approval. Additional railroad crossings, especially across main line track, will not be allowed if alternative access is available.

Where additional railroad crossings are allowed, they shall be designed in accordance with the 2001 AASHTO Green Book, "Railroad-Highway Grade Crossings" pages 735 through 745.

#### Q. Curb and Gutter

1. Cement Concrete Curb and Gutter shall be utilized for street edges under the following conditions:
  - a. In areas where urban road standards are to be used.
  - b. On frontages with commercial usage.
2. Rolled edge, thickened edge or mountable curbs are not permitted as a substitute for curbs and gutters except on private roads, and may only be used in rural areas when approved by the County Engineer.
3. On all sections constructed with curb and gutter a closed drainage system consisting of catch basins, storm sewer pipes and manholes shall be required unless alternative and appropriately designed methods of collecting and dispersing stormwater such as bio-infiltration swales and drywells are provided.
4. Curb and gutter shall be constructed in accordance with WSDOT Standard Plan F-1 and F-1a.

#### R. Sidewalks

1. Sidewalks shall be provided on both sides of all arterials, collectors, local access roads and commercial streets in urban areas. Sidewalks shall be required on only one side of the road on all perimeter arterial and major and minor collectors or half-roads of a development being constructed under urban standards.
2. Alternatives to requirements R.1. may be approved under the provisions of Chapter 12.50.100 of these standards. Typical conditions that may warrant approval of an alternative or waiver of the requirements include existing streets where it would be unduly difficult or impractical to construct sidewalks due to grade or steep slope problems or in developments where the basic design allows for an off-road walkway system provided that said walkway is an improved surface and provision for maintenance is guaranteed.
3. Sidewalks shall be constructed with Portland Cement Concrete. Sidewalks shall be at least five feet in width and four inches in thickness for urban local access

streets. Urban collector and urban arterial sidewalks shall be at least six (6) feet in width. When adjacent to school property and in commercial areas, the sidewalks shall be at least eight (8) feet in width. Sidewalk configurations shall be in accordance with the WSDOT Design Manual and the WSDOT Standard Plans F-3 except for sidewalk width. All sidewalk ramps and features shall be ADA compliant.

### **12.52.050 Stormwater Management**

- A. All project submittals shall be in compliance with the provisions of DCC Chapter 20.34 “Stormwater Drainage”. In addition, all drainage facilities within current or future County right of way must be of the type and nature that can be easily maintained by the County. This typically includes as a minimum 12-inch diameter storm sewer pipe and standard catch basins and manholes for curb and gutter roadway sections. All other facilities such as French drains, curtain drains, drywells and stormwater detention ponds shall be installed outside the County’s right of way and be maintained by the applicant or homeowner’s association. See also Chapter 12.55.050 “Plan Elements”, Item J “Standard Plan Notes” for catch basin and grate requirements.
- B. All cross culverts and ditch channelizations shall be first evaluated for the presence of fish and, should it be determined by the County that the culvert or channelization be designed to accommodate fish passage including stream bed and/or stream bank enhancement, the culvert or channelization shall be constructed to meet current Washington State Department of Fish and Wildlife standards.
- C. Stormwater facilities shall also be designed to accommodate the stormwater from the addition of frontage improvements including tributary area. In locations where future development is expected at a higher elevation and adjacent to the proposed development, the storm sewer pipe shall be extended and deadheaded at the development property line to ease future system connection.
- D. Projects requesting stormwater management fee credit from the County for the stormwater facilities as provided for in DCC Chapter 19.40, “Surface and Storm Water Management Utility Code” shall be required to provide the County with a Project Engineer’s Certification of the facilities prior to release of the financial security. The financial security shall not be released until all facilities are completed and repaired as per the approved plans.
- E. The maximum spacing on surface drainage courses between inlets or catch basins shall normally be 150 feet on road grades less than 1.0% and 200 feet on grades from 1.0% to 3.0%. When the road grade is greater than 3.0%, the maximum spacing shall be 300 feet. Additional catch basins may be required to confine drainage to the gutter and prevent road drainage from sheet flowing across roadways or intersections. The applicant shall locate any additional catch basins or make other drainage system

improvements to insure that any road drainage does not encroach more than one-half the traveled way lane width nor exceed one-half the curb height during a rainfall design event of 2 inches in 90 minutes. Maximum spacing on main storm sewers between access structures, whether catch basins or manholes, shall be 300 feet.

F. All materials used shall conform to the requirements of the Standard Specifications.

### **12.52.060 New Utilities**

#### **A. Location of Utilities - Underground**

1. Underground utilities to be installed within the right-of-way on new roads (or on roads where existing topography, utilities or storm drains are not in conflict), shall be located as shown in Figures 3-10 and 3-11. Where existing utilities or storm drains are in place, new utilities shall conform to these standards as nearly as practicable and yet be compatible with the existing installations. Utilities to be installed outside the road right-of-way shall be installed within a designated utility easement and shall meet the installation requirements of the utility.
2. Gravity systems, whether sanitary or storm drainage, shall have precedence over other systems in planning and installation except where a non-gravity system has already been installed under previous approved permit and subject to applicable provisions of such permits or franchises.
3. Individual water service lines shall:
  - a. Be placed with minimum 36-inch cover from finished grade, ditch bottom or natural ground.
  - b. Use road right-of-way only as necessary to make side connections.
  - c. For any one connection, not extend more than 60 feet along or through the right-of-way, or the minimum width of the existing right-of-way.
  - d. Water meter boxes, when placed or re-placed, shall be located on the right-of-way line immediately adjacent to the property being served, unless otherwise approved by the County Engineer. Meter box locations within the right-of-way may be approved by the County Engineer based on site conditions that make routine service access difficult or impractical.
4. Sanitary Sewers:
  - a. In the case of individual sanitary sewer service lines which are force mains the pipe shall:

- (1). Be minimum two inches I.D., or as required by the utility to maintain internal scouring velocity.
  - (2). If nonmetallic, contain wire or other acceptable proximity detection features; or be placed in a cast iron or other acceptable metal casing.
  - (3). Be placed with minimum three-foot cover from finished grade, ditch bottom or natural ground, within 10 degrees of perpendicular to road centerline, and extend to right-of-way line.
- b. Sanitary and water lines shall be separated in accordance with good engineering practice such as the Criteria for Sewage Work Design, Washington Department of Ecology, latest edition.

5. Service Connections - all

Mains and service connections to all lots shall be completed prior to placing of surface materials.

6. Materials and Installation – all

All underground utilities shall utilize materials and be installed in conformance with the requirements of the particular utility standards.

B. Location of Utilities – Above Ground

1. All poles, transformer cases, and other above ground utility appurtenances shall be located to avoid becoming a roadside obstacle. See Chapter 12.57.080 for further guidance.
2. Above ground utilities located within intersections shall be placed so as to avoid conflict with placement of curb ramps

**12.52.070 Connections to Existing Utilities**

Typically, new utility installations, both underground and overhead, constructed in conjunction with land development require a connection to existing utilities. Where such connections must utilize existing county right of way, the connection must be performed in accordance with the County's Accommodation of Utilities on County Road Right of Way, DCC Chapter 12.20.

## ***Part 4 – Driveways, Access Easement, Pedestrian Facilities, Walks and Trails***

### **12.53.010 Driveways and Access Easement**

#### **A. General**

1. Driveways and access easements are defined as in DCC Title 14.98.
2. Dimensions, slopes and details for all driveway and access easements connecting to a county road shall be as indicated on Figure 4-1. Driveways entering roads with curb and gutter shall meet the requirements of WSDOT Standard Plan F-4.
3. All new or revised driveways and accesses onto a County road (including temporary or construction accesses) require an approved access permit as per the procedures in DCC Title 12.24 “Approaches to County Roads”.

#### **B. Conditions for Approval of New Driveways and Access Easements**

1. Driveways directly providing access onto arterials and collectors shall be denied if alternate access is available. Access onto arterials and collectors may be permitted where no other alternative is available and is approved by the County Engineer.
2. Where property has frontage on more than one roadway, driveways and accesses shall be limited to the lowest volume roadway.
3. Driveways and access easements shall have a minimum separation from each other of one hundred (100) feet in rural areas outside of subdivisions.
4. Circular driveways shall have a minimum separation of 100 feet.
5. In Urban areas, driveways and access easements should be located not less than one hundred fifty (150) feet from the nearest intersecting road as measured from the property corner.
6. In areas zoned residential, the minimum separation of individual parcel driveways or accesses, as measured from the centerlines of the driveways or accesses, shall not exceed one-half of the sum of the accessed parcel frontage and each of the adjacent parcel frontages. Joint usage driveways may be required where sufficient spacing is not available
7. Only one driveway per single residential or commercial unit will be permitted unless the applicant can demonstrate that additional driveways or accesses are needed due to the amount of traffic generated by the project, traffic

distribution patterns, impacts to the county road system or public safety and there is sufficient space to accommodate the additional driveway or access. Joint usage driveways are encouraged.

8. All abandoned driveways shall be removed and restored by the applicant or agent.
9. Maintenance of driveways and approaches (and associated culverts where required) onto a County road shall be the responsibility of the applicant.

C. Standards

1. Common to all driveways and access easement.
  - a. Clear View Triangle

In addition to providing sufficient sight distances as required in part c. following of this section, a clear view triangle as described in DCC Title 12.28.040 shall be maintained for vision safety purposes.

- b. Alignment

All driveways and access easement shall intersect the main roadway at an angle between 75 and 105 degrees, with 90 degrees being preferable.

- c. Sight Distance

Sufficient sight distances for vehicles to safely enter onto a public road or street as well as for other vehicles on the road or street to avoid accidents with entering or exiting vehicles is required for all driveways and access points. For all driveways and access easement, stopping sight distance in accordance with the 2001 AASHTO Green Book is required as follows:

To calculate sight distance for existing roads serving a proposed driveway or access, first convert the posted speed to an operating speed as per Table 4-1:

**Table 4-1**

Posted Speed	Add for Operating Speed
20 mph	0
25 mph	0
30 mph	5 mph
35 mph	8 mph
40 mph	10 mph
45 mph and above	10 mph

Secondly, use the operating speed and determine the minimum stopping sight distances from Table 4-2 (based on an approaching vehicle driver's eye height of 3.5 feet and an object at the driveway of 2.0 feet).

**TABLE 4-2**

Operating Speed mph	Minimum Stopping Sight Distance ft.
20	115
25	155
30	200
35	250
40	305
45	360
50	425
55	495
60	570

The grade of the road can also affect the minimum sight distance required. The following Table 4-3 provides the increase for downgrades and the decrease for upgrades modifiers.

**Table 4-3**

Operating Speed mph	Increase (ft) for downgrades			Decrease (ft) for upgrades		
	3%	6%	9%	3%	6%	9%
20 to 30	10	20	30	---	10	20
31 to 40	20	40	70	10	20	30
41 to 50	30	70	---	20	30	---
51 to 60	50	110	---	30	50	---

Situations with sight distances less than the above must be approved by the County Engineer. In these cases, the applicant may also be required to obtain the services of a professional traffic engineer to assess the situation and provide written justification for lesser sight distances.

Sight distances shall be measured from a point ten (10) feet back of the edge of shoulder or back of sidewalk each way along the edge of the traveled way of the main roadway as shown in the figure below.

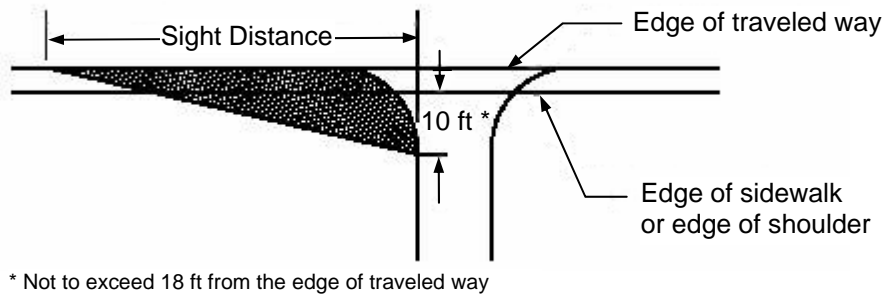

d. Drainage

Approaches shall be constructed in such a manner as to minimize the runoff from a driveway or other access easement onto the main road.

All approaches at points where there is an existing roadside ditch shall be constructed with a culvert pipe meeting the specifications of the County Engineer.

e. Surfacing Within Right of Way

That portion of a driveway or access easement connecting to a paved public road that is within the right of way of the public road shall be surfaced with a minimum of two and one half (2-1/2) inches of compacted asphalt concrete pavement or equivalent surfacing material to the road.

f. Maintenance

Maintenance of all driveways and access easement including approaches to public roads shall be the responsibility of the owner(s).

2. Driveways and Joint Usage Driveways

Urban or Rural driveways and joint usage driveways serving two or fewer lots have no minimum width or surfacing requirements beyond requirements of Chapter 12.53.010 C1.

3. Access Easements

Property accesses serving three or more lots and are more than one hundred fifty (150) feet in length as measured from the connecting road near side right of way line to the farthest exterior wall of an occupied unit are access easements. Unless an alternate approved emergency vehicle access is provided, access easements shall also serve as an emergency vehicle access. Access easements are privately owned and maintained by the property owners

being served and are not the responsibility of the County. Access easements shall have the following requirements and detailed on figure 4-3:

- a. The minimum width of the tract for the access easement shall be thirty (30) feet.
- b. The base and surfacing shall provide a minimum traveled way of twelve (12) feet with turnouts one every 300-500 feet depending on line of sight, for fifty (50) feet in length of twenty (20) feet in width and be designed and constructed as an all-weather road. A hammer head or cul-de-sac needs to be provided for turn around. The minimum base and surfacing shall be six (6) inches of compacted gravel base, crushed surfacing base course or crushed surfacing top course. A 20' wide clear zone will be provided full length for access easement.
- c. Suitable drainage in the form of ditches and cross culverts shall be provided along the full length of the access easement. Any bridges or drainage structures shall meet the requirements of DCC 12.55.
- d. The length of an access easement within an urban growth area shall not exceed four hundred fifty (450) feet, excluding the turnaround unless otherwise approved by the County Fire Marshal, and shall not serve more than three (3) lots. Access easement to more than three (3) lots within an urban growth area shall be via an urban local access county or private road meeting the requirements of DCC 12.53 as included in these Standards.
- e. Access easements outside of an urban growth area shall not serve more than eight (8) lots or parcels. Access easement to more than eight (8) lots outside an urban growth area shall be via a rural local access county or private road meeting the requirements of DCC 12.53 as included in these Standards.
- f. The minimum centerline radius of curvature shall not be less than forty five (45) feet, provided however, if an approved alternate emergency vehicle access is provided, the minimum centerline radius of curvature shall not be less than thirty (30) feet.
- g. The maximum grade shall be ten (10) percent for gravel surfacing and twelve (12) percent for paved portions.
- h. The minimum clear vertical distance shall not be less than thirteen feet, six inches (13'-6").
- i. All dead end access easements greater than one hundred fifty (150) feet in length shall be improved with an approved turnaround for emergency

vehicles such as a cul-de-sac or hammerhead. See Figure 4-2 for acceptable turnaround designs.

#### **12.54.010 Pedestrian Facilities (Urban areas)**

Sidewalks are required on both sides of urban streets. See Chapter 12.53.040 R for details and exceptions.

#### **12.54.020 Walkways, Bikeways and Trails**

Walkways, bikeways and trails shall be required as identified in the applicable comprehensive plan or separate Non-Motorized Transportation Plan.

Non-motorized transportation includes travel by bicyclists, pedestrians, and equestrians. Sections 1020 and 1025 of the WSDOT Design Manual will be followed for design of bicycle paths, trails and other non-motorized transportation.

#### **12.54.030 School Access**

Sidewalks for school access shall be provided in accordance with the safe walking plans as developed by individual schools and school districts. In addition, walking paths or sidewalks will be required in new plats to facilitate access to schools.

#### **12.54.040 Alleys**

Where provided, every alley at the rear of a lot shall have a minimum width of twenty (20) feet. Structural and surfacing requirements shall be the same as the adjoining streets. No dead-end alley or alley with sharp changes in direction shall be permitted.

## ***Part 5– Bridges and Drainage Structures***

### **12.54.010 Design Standards**

- A. All culvert pipe, box culverts, and bridges shall conform to the following:
  - 1. AASHTO Standard Specifications for Highway Bridges, latest edition and applicable interim versions.
  - 2. WSDOT, Standard Specifications for Road and Bridge Construction, latest edition.
  - 3. WSDOT, Bridge Design Manual, latest edition
  - 4. WSDOT, Bridge Detailing Manual, latest edition.
- B. A hydraulic analysis shall be performed for all culverts, open channels and box culverts in accordance with the WSDOT Hydraulics Manual. Such drainage structures shall be sized and located as per the analysis, provided however, that no cross culvert shall be less than eighteen (18) inches in diameter.
- C. All bridges shall be constructed of reinforced concrete. Spans may be pre- or post-tensioned concrete girders or beams with a concrete deck. Steel or other metal bridges may be used only with the approval of the County Engineer. Treated timber bridges may be used on private roads only.
- D. Bridge clear width shall accommodate the full width of the traveled lanes, parking lanes and shoulders of approach roads. Bikeway and pedestrian walkways shall be provided where required.
- E. All roadway structures must be designed for a minimum HS20-44 loading, however new bridges on private roads may be designed for a HS20 loadings and a minimum width equal to the traveled way plus two (2) feet.
- F. All box culverts and bridges shall have the year of construction permanently indented on the downstream headwall face in legible numbers. The numbers shall be 3" high by 1-1/2" wide by approximately 3/8" deep in the headwall face.
- G. All box culvert, pipe arch, structural plate culverts and bridge designs shall be done by a registered professional structural engineer licensed in the State of Washington. The complete design of the structure shall be submitted to the County Engineer for approval.
- H. Foundation designs shall be based upon the recommendations of a qualified geotechnical engineer and shall include a scour analysis for the protection of

existing streambed and footing elevations. These recommendations shall be documented in the geotechnical report which shall accompany the bridge design documents.

- I. A new structure shall not create a backwater elevation rise of more than one foot. The bottom of the superstructure of bridges shall be a minimum of three feet above the one hundred year flood elevation.
- J. Various permits may be required and are the responsibility of the applicant. Such permits may include, but are not limited to, the following:
  - 1. Bridges over navigable waters require U.S. Coast Guard permits.
  - 2. Bridges involving deposition of material in waters of the United States or their adjacent wetlands require a U.S. Army Corps of Engineers Permit.
  - 3. Any work involving alteration of flow or bed materials below the ordinary high water line of any water body or water course requires a Hydraulic Project approval from the State Department of Fish and Wildlife.
  - 4. Any project requiring a U.S. Army Corps of Engineers Permit also requires a Water Quality Certification from the State Department of Ecology.
  - 5. Bridges across streams in State Flood Control Zones require a permit from the State Department of Ecology.
  - 6. Where Bridge structures lie on or over submerged lands, a lease from the Washington State Department of Natural Resources may be necessary.
  - 7. Structures located on shoreline zones as defined in the Douglas County Shoreline Master Program require a substantial development permit from Douglas County, subject to concurrence of the State Department of Ecology.
  - 8. Structures in Critical Areas as defined in DCC Title 19 require Critical Area permits from Douglas County.

#### **12.54.020 Inspections**

The developer and his engineer are responsible for inspection, quality control and sufficiency of the completed structure subject to approval by the county engineer. All materials and testing thereof shall conform to the current edition of the WSDOT Standard Specifications. Prior to construction, the County Engineer shall review with the developer's engineer the required inspections and documentation required.

### **12.54.030 As-Built Plans**

Upon completion and acceptance of any box culvert or bridge built under these standards, a complete set of as-built plans shall be furnished to the County Engineer. See DCC 12.55.060 for further guidance.

### **12.54.040 Existing Bridges and Drainage Structures**

- A. Prior to any land division approval and as directed by the County Engineer, an inspection of existing bridges and drainage structures within the boundaries of the development shall be conducted by a licensed professional structural engineer knowledgeable of bridge design, construction and load ratings. The engineer shall submit a report indicating the condition of the existing bridge as to the requirements set forth in these standards in regards to load function, superstructure and abutments.
- B. Existing bridges and drainage structures within the boundaries of the development that do not meet the standards of this section shall be replaced with new bridges and drainage structures or the existing bridges and drainage structures shall be modified as necessary.
- C. Should the development review process identify off-site locations where the existing roads must be widened or realigned as a condition of development approval (see DCC 12.50.150), all affected bridges and drainage structures shall be evaluated in the same manner as for those within the boundaries of the development? All necessary widenings, extensions or replacements necessary to accommodate the new roadway width or alignment and meeting both the structural and hydraulic adequacy as set forth herein shall be designed as set forth in 12.54.010 of this section.

## ***Part 6 – Construction Plans***

### **12.55.010 General Requirements**

All construction plans and drainage reports, soils reports and pavement designs shall be prepared by, or under the direction of, a professional engineer, registered in the State of Washington, and shall be reviewed for the minimum requirements set forth herein. The engineer should be aware that whenever unusual or serious problems are anticipated in conjunction with a proposed construction project, additional information and analysis beyond the minimum requirements of these specifications and criteria will be required. In all cases, the engineer shall comply with all local, State and Federal regulations applicable to the project.

### **12.55.020 Certification**

- A. Construction plans submitted for review and comment shall be prepared by a professional engineer, registered in the State of Washington. The plans must include the following statement on the cover sheet:

*These construction plans for (name of subdivision, development, or project) were prepared by me (or under my direct supervision) in accordance with the requirements of the Douglas County Road Standards*

*Name of Engineer*  
*Name of Firm*  
*Date*

The statement shall be signed and stamped by the Registered Professional Engineer who prepared or directed preparation of the construction plans.

- B. Unless otherwise identified or noted, all construction plan submittals are assumed to comply with the provisions of this manual. Alternatives to these standards may be requested as set forth in Part 1. Failure to follow prescribed procedures may result in return of submittals, additional review fees, or both.
- C. Douglas County shall not be responsible for the accuracy and adequacy of the design or dimensions and elevations on the plans. Douglas County, through the acceptance of the construction plan or drainage report and other supporting documents, assumes no responsibility for the completeness and/or accuracy of the construction plan or drainage report. The cover sheet shall bear the following statement:

*The engineer who has prepared these plans, by execution and/or seal hereof does hereby affirm responsibility to the County, as a beneficiary of said engineer's work, for any errors and omissions contained in these plans, and approval of*

*these plans by the County Engineer shall not relieve the engineer who has prepared these plans of any such responsibility.*

#### **12.55.030 When Plans are not Required**

Subject to review, the county may waive plan requirements, wholly or in part, based upon the following criteria:

For improvement to existing public roads if each of the following requirements are met:

- A. No more than 5,000 square feet will be cleared and graded within the right-of-way or easement, and
- B. The existing road grade does not exceed 10%, and
- C. The existing road has a uniform cross section, and
- D. The work does not intercept a stream or wetland or otherwise impact natural surface drainage as set in County Code regarding critical areas, shorelines and surface water; and
- E. Plans do not include a retention/detention facility within the right-of-way; and
- F. Douglas County standard drawings, submitted with required permits, are sufficient to describe the improvement to be constructed.

#### **12.55.040 Submittal Procedure**

Plans for proposed road and drainage construction shall be submitted to the Department of Transportation and Land Services as follows:

- A. The first submittal shall consist of three (3) complete sets of prints together with drainage calculations and other necessary supporting information, and shall be signed and stamped by the applicant's engineer. The applicant's engineer must be a registered engineer in the State of Washington. Review fees, when applicable, shall be paid by the applicant before review of the plans by the County commences.
- B. If corrections are required, the County will return a redlined print showing necessary corrections. When corrections are required, the applicant's engineer shall return the redlined print with the corrected plans.
- C. Subsequent submittals shall also contain three (3) complete sets of plans and other supporting information, if corrected. When all corrections have been made to the County Engineer's satisfaction, the original Mylar set of plans will be signed and

returned to the applicant's engineer. The final plans will require stamping and signature of the applicant's engineer.

- D. The applicant's engineer shall provide the County with a good quality reproducible Mylar with the applicant's registration stamp and signature plus two complete sets of prints of the approved plans and one complete set of other supporting documentation. Where plans are prepared in an electronic format such as AutoCad or another format acceptable by the County, the applicant's engineer shall also provide copies of the electronic data files to the County. The applicant's engineer shall also provide a quantity take-off and engineer's cost estimate of proposed construction when the project is to be secured by some form of performance guarantee.
- E. Plans will be reviewed by the County according to the date they were submitted. Previously reviewed or approved plans submitted to the County for a revision will be considered a new submittal. Approved plans under construction will be considered a resubmittal and will be reviewed prior to new submittals.

#### **12.55.050 Plan Elements**

The following plan elements shall be provided on all construction plans:

##### **A. Vicinity map**

Minimum scale is 1"=1000' showing the location and name of all arterial roadways within one mile of the proposed construction, and all other roadways in the vicinity of the proposed construction. Shading shall indicate the project area. This map is required on the cover sheet or first sheet of all submittals, if no cover sheet has been used. The vicinity map shall show all arterial roadways and major drainage ways. Section, Township, and Range shall also be shown.

The minimum size of the vicinity map shall be 10" x 10".

##### **B. Title block**

A title block is required on every sheet and cover sheet submitted for review and acceptance. The subdivision name and filing number; Planned Development name (if applicable); the type of improvement; name, address, including zip code, and telephone number and name of the consulting engineer; name, address, including zip code, telephone number and name of the contact person at the developer; and sheet number (consecutive, beginning with the cover sheet) shall be included in the title block. The title block shall be located in the extreme lower right hand corner, the right side margin, or along the bottom edge of the sheet.

The title block must also have sufficient space to show the nature, date and approval of all revisions.

The original date of the plans and any subsequent revisions must be shown in the title block.

C. Acceptance block

1. All roadway construction plans, storm sewer or other drainage improvement construction plans, and privately or publicly maintained storm water detention or retention facility construction plans must show the acceptance signature of the designated representative of the County Engineer. Where there are existing utilities within the right-of-way, an additional acceptance block for each utility shall be included.
2. Plans for traffic control during construction must be accepted prior to issuing construction permits.
3. Plans for construction stormwater pollution prevention must be accepted prior to issuing construction permits.
4. Signing/Striping plans require acceptance prior to issuing construction permits.
5. The acceptance block shall be located in the lower right hand quadrant of the cover sheet.
6. Acceptance block shall be as follows:

*“These plans have been reviewed by Douglas County Department of Transportation and Land Services and have been accepted for complying with the requirements of Douglas County Road Standards. These plans are valid for three years from the date of acceptance.”*

\_\_\_\_\_  
*County Engineer*

\_\_\_\_\_  
*Date*

D. Scale

The following scales are the minimum required. More detailed scales will be required where necessary to clearly show details.

1. Plan and profile plans: Horizontal 1"=50', Vertical 1"=5'.
2. Master, preliminary, and final drainage plans; site plans, etc.: from 1"=50' to 1"=100'.

E. Seal/signature

The seal and signature of the owner's engineer, under whose supervision the plans were prepared, shall be located next to the Acceptance Block on each sheet.

F. Utilities

The type, size, location and number of all above ground and underground utilities shall be shown. Field verified elevations and locations may be required on the construction plans for all underground utilities which will potentially affect the design or construction. It will be the responsibility of the contractor to verify the existence and location of all underground utilities along their route of work prior to commencing any new construction. Field located utilities not shown on accepted construction plans shall be added to the record (as-built) drawings submitted as a condition of conditional acceptance of the public

G. Private improvements

1. Private improvements such as roadways, driveways, utilities, etc. shall be clearly shown and labeled as such on each sheet of the construction plans. The note below shall appear on the cover sheet of the construction plans for private improvements:

*Douglas County shall not be responsible for the maintenance of roadway and appurtenant improvements, including storm drainage structures and pipes, for the following private roads: (list).*

2. When a request is made for the County to assume maintenance of any private improvement, it shall be the responsibility of the person(s) making the request to satisfactorily demonstrate that the private improvement is in fact constructed in accordance with the current Douglas County Roadway Standards for county roads. In addition, all necessary right-of-way must be transferred to the County and the road established by the Board of County Commissioners as per RCW.
3. Douglas County will not accept maintenance responsibilities for private road improvements associated with land development activities. In no case shall private improvements not constructed in accordance with the applicable design and construction standards and specifications be accepted for maintenance by Douglas County.

## H. Road plan, profile elements and details

In addition to the requirements set forth elsewhere in these standards, the following information shall be shown on all roadway plans submitted for review and approval.

1. Plan View - The plan view shall include, but not be limited to, the following:
  - a. Existing and proposed Property and/or R.O.W. lines, easements and/or tracts and/or irrigation ditch(s). Type and dimension of easement or tract is to be clearly labeled. R.O.W. lines with individual parcel or lot frontages are to be dimensioned.
  - b. Survey lines and stations shall normally be based on centerline of street; other profiles may be included but shall be referenced to centerline stationing.
  - c. Roadways and roadway names.
  - d. North arrow
  - e. Roadway alignments with 100-foot stationing, reading from west to east/south to north including stationing and dimensions of all roadway width variations from the typical roadway section(s).
  - f. All topographic features with right of way limits and sufficient area beyond to resolve questions of setback, slope, drainage, access onto abutting property, and road continuations. A minimum of 100 feet shall be shown on either side of centerline and a minimum of 200 feet shall be shown from the terminus of the road, or such additional terrain as directed by the County Engineer.
  - g. Existing utilities and structures, including, but not limited to:

Storm sewer & appurtenances, fence lines & gates, water lines & appurtenances, irrigation, ditches or swales, electric lines & appurtenances, curbs and gutters, sewer lines & appurtenances, pavement limits, telephone lines & appurtenances, bridges or culverts, cable television lines & appurtenances, guardrails, signs, gas lines & appurtenances, etc.
  - h. Station and critical elevation (flow line, invert of pipe, etc.) of all existing and proposed utility or drainage structures. Location of utilities shall be dimensioned horizontally and vertically from roadway centerline profile grade.

- i. Storm drainage flow direction arrows, particularly at intersections and all high and low points.
  - j. Match lines and consecutive sheet numbers, beginning with cover sheet.
  - k. Station and elevation of all horizontal curves including PI, PC's, PT's, etc.; high or low point and PI of all vertical curves; existing and proposed, centerline bearings, distances, and complete curve data including superelevation data and pivot point locations.
  - l. Curb return radii, existing and proposed including stations and elevations of all curb returns; mid point elevations, and flow line-flow line intersection elevations and grades.
  - m. Mid-block handicap ramp locations at tee intersections.
  - n. Centerline stations of all non-single family residential driveways and all intersecting roadways.
  - o. Survey tie lines to section corners or quarter corners, consistent with that shown on the plat.
  - p. Typical roadway cross section for all roadways, existing or proposed, within and adjacent to the proposed development. These cross sections shall appear on the detail sheet, or if no detail sheet has been used, the first sheet of the submittal showing roadway design. They shall indicate type of roadway(s), profile grade design point (centerline, flow-line, top of curb, lip of gutter, etc.), roadway width, right-of-way, type of curb, gutter and walk, pavement cross slope, pavement thickness, and structural material components of the pavement, base and sub-base, together with specifications for treatment of subgrade and installation of pavement structural members.
  - q. Construction plans for arterial improvements. Any roadway intersecting an arterial, or any collector intersection requiring signalized traffic control shall include construction and lane details for the new construction and existing facilities a minimum of 150 ft beyond the limits of construction.
2. Profile - The profile shall include, but not be limited to, the following:
- a. Original ground (dashed) and design grade (heavy, solid). Both grades are to be plainly labeled.
  - b. All design elevations shall be centerline, top of curb, lip of gutter, or flow line (preferred) for 6 in. vertical curb and gutter; or back of walk, or lip of gutter, or flow line (preferred) for combination curb, gutter and walk. The

basis of record drawing information shall be the same as the design (both flow line or both top of curb, etc.). Ditch profiles may be required for rural road sections at the discretion of the County Engineer.

- c. Stationing continuous for the entire portion of the roadway shown in the plan view, with the centerline station of all non-single family driveways and all intersecting roadways clearly labeled.
  - d. All existing curbs, gutters, sidewalks and pavement adjacent to the proposed design. Basis for existing grades shall be as-built elevations at intervals not to exceed twenty-five (25) feet. Previously approved designs are not an acceptable means of establishing existing grades.
  - e. Existing and new utilities. Elevation and location of all utilities in the immediate vicinity of the construction shall be shown on the plans.
  - f. Station and elevation of all vertical grade breaks, existing (as-built) and proposed.
  - g. Distance and grade between VPI's.
  - h. Vertical curves, when necessary, with VPI, VPC, and VPT, high or low point (if applicable) stations and elevations. All vertical curves shall be labeled with length of curve (L) and  $K=L/A$  where A is the algebraic difference in slopes, in percent.
  - i. Superelevation data including pivot point locations shall be required and included for all roadways with a design speed of 30 miles per hour or higher.
  - j. Profiles for all curb returns (except medians).
3. Details - All details necessary for a complete set of plans that are not covered by reference to the WSDOT Standard Plans such as walls, special drainage elements, major culverts, etc. shall be included in the plans.
4. Standard Plans – The submitted plans shall include copies of all WSDOT Standard Plans referenced within the plans.

#### I. Temporary Erosion Control Plan

A temporary erosion/sedimentation control plan, showing the location and control measures intended to minimize the effects of erosion and siltation due to construction operations shall be submitted with the construction plans and shall conform to the requirements of the WSDOT Standard Specifications.

## J. Notes

In addition to other notes required in these Standards, the following notes shall appear on the cover sheet of all submittals containing roadway plans:

### **Standard Plan Notes**

1. All materials and workmanship shall be in accordance with the requirements of the most current edition of the State of Washington, Department of Transportation Standard Specifications for Road and Bridge Construction and Douglas County Road Standards.
2. Catch basins shall be Type 1 or Type 2, WSDOT Standard Plans, with standard, vaned or herringbone frame and grate unless otherwise noted. The outside edge of the catch basin shall be placed at the intersection of the curb and gutter and 0.010' to 0.015' below finished grade, or in the gutter line of the rolled edge section.
3. If adequate inspection is not completed and documented before completion of the roadway construction, it may be necessary for core drilling and testing to be performed to assure an acceptable quality of roadway. When core drilling is found to be necessary, the applicant will be held responsible for all costs incurred.
4. It will be the applicant's responsibility to contact all utility companies in order to assure that all lines, pipes, poles and other appurtenances are properly located and their installation is coordinated with the road construction. All utility relocation work shall be at the expense of the applicant and must be in accordance with Douglas County Road Standards prior to road acceptance.
5. Culvert pipe shall be galvanized steel or plastic (ADS smooth wall) 12- inch diameter minimum pipe with beveled ends unless otherwise noted. Beveled ends shall match the in-slope in the ditch line or match the slope in a cut or fill section.
6. Buried utilities are shown in their approximate location. The applicant shall have the utilities verified on the ground prior to any construction.
7. Onsite erosion control measures shall be the responsibility of the applicant and be in place prior to construction. Any problems occurring before final acceptance by Douglas County and within 24 months thereafter shall be corrected by the applicant. At the end of the 24 month period, or as otherwise directed by the County Engineer, the applicant shall remove all temporary, non-degradable erosion control measures.
8. The applicant shall be responsible for controlling all fugitive dust that may be generated by the construction project.

9. Any revisions to plans must be made by the applicant's engineer and approved by the County Engineer prior to any implementation in the field.
10. All pavement markings shall conform to the requirements of the MUTCD.
11. Before striping takes place the applicant shall contact the Douglas County Transportation and Land Services office for coordination of the striping.
12. A copy of the approved plans must be on the job site whenever construction is in progress.
13. Slopes shall be stabilized to prevent erosion. In case erosion occurs in ditches, ditch lining is to be provided as requested and specified by the County.
14. Where newly constructed paving meets existing paving, the applicant shall overlay and feather new pavement to provide a smooth transition from existing to proposed paving. Application of a thin tack coat of emulsified asphalt shall be applied to insure proper bonding.
15. The completed surface of all courses shall be of uniform texture, smooth, uniform as to crown and grade, and free from defects of all kinds. The completed surface of the wearing course shall not vary more than 1/8 inch from the lower edge of a 10-foot straightedge placed on the surface parallel to the centerline. The transverse slope of the completed surface of the wearing course shall vary not more than 1/4 inch in 10- feet from the rate of transverse slope shown on the plans.
16. Materials sampling and testing shall be at a frequency and magnitude as specified in the Standard Specifications or determined by the County Engineer. In the case of plat roads, a private and independent testing laboratory shall perform testing and sampling. Certified test reports shall be furnished for all tests performed by private testing laboratories.

#### K. Signing and striping Plan

Permanent signage and striping shall be complete and in place before any new roadway is opened to the public. Traffic signal installation and equipment shall conform to the Washington Department of Transportation Standards and Specifications. The Manual on Uniform Traffic Control Devices Signal Warrants shall be met for signal installation. All subdivisions, road improvement projects, and/or commercial development must incorporate a separate signage and striping plan in accordance with the following criteria:

1. Submittal - Separate signage and striping plans are to consist of an overall area map noting all specific use areas, such as schools, parks, recreation centers, library, commercial, industrial, etc. The pages following the area map are to be broken down into road segments, for notation of signage and striping details.
2. Sign Warrants - Traffic control devices which are not warranted by MUTCD shall not be installed. When MUTCD guidelines are not applicable for a given case, a traffic engineering study by the owner's engineer will be required. This study will address the existing conditions, safety issues, and the applicable warrants.

L. Monuments and benchmarks

See 12.58.040 "Survey Monuments"

**12.55.060 General Standards for Subdivision Final Construction Plans**

The following general standards shall be met for final construction plans.

1. All road and storm sewer construction must conform to the Douglas County road and stormwater standards current at the time of plan approval.
2. All traffic control devices must conform to the Manual on Uniform Traffic Control Devices.
3. Prior to release of collateral by Douglas County the developer must present a statement from an engineer registered as a professional engineer in the State of Washington that the project has been completed in substantial compliance with approved plans and specifications and documenting that the engineer has made regular on-site inspections during the course of construction, and the field plans utilized were the same as those approved by Douglas County. The engineer shall also state that quality control testing has been undertaken for the project, which testing demonstrates compliance with the plans and specifications approved by Douglas County. The developer must also submit the following items prior to release of collateral:
  - a. "As-built" plans for the improvements must be submitted at the time the letter requesting collateral release is submitted. The "as-built" plans must be clearly labeled as such, and must be signed and dated by a registered professional engineer. They must show any deviations from the approved plans. Release of collateral will not occur if the County Engineer determines deviations are present which have not received prior approval.
  - b. A letter or letters of acceptance and responsibility for maintenance of the improvements by the appropriate utility company, special district, or town for all utilities and roads.

- c. A letter from the appropriate fire authority stating that fire hydrants, where required, are in place in accordance with the approved plans. The letter shall also state that the fire hydrants are operational and, if required by the Fire Marshal, provide the results of fire flow tests.
  
- d. For roads under consideration for adoption to the county road system: Quality control test results must be submitted for all phases of the project in accordance with Washington State Department of Transportation's schedule for minimum materials sampling, testing, and inspection as found in the WSDOT Materials Manual. The County Engineer shall review and approve a proposed schedule of testing before commencement of construction.

## ***Part 7 – Construction Control and Inspection***

### **12.56.010 Basis for Control of the Work**

- A. Work performed in the construction or improvement of County roads, whether by or for a private developer, by County forces, by County Contractor or by private contractor, shall be done in accordance with these Standards and approved plans. **IT IS EMPHASIZED THAT NO WORK MAY BE STARTED UNTIL SUCH PLANS ARE APPROVED.** Any revision to such plans shall be approved by the County Engineer before being implemented.
- B. The County Engineer will have authority to enforce the Standards as well as other referenced or pertinent specifications.
- C. Provisions of Section 1-05 of the WSDOT Standard Specifications shall apply, with the term “Engineer” therein construed to be the County Engineer as defined in these Standards.
- D. Unless otherwise approved or directed, all construction work shall be done in accordance with the WSDOT Standard Specifications.

### **12.56.020 Hours of Work**

Unless otherwise approved by the County Engineer prior to beginning construction, the normal work hours for construction are as follows:

Monday through Friday	6:00 am to 7:00 pm
Saturday	7:00 am to 7:00 pm
Sunday	8:00 am to 7:00 pm

### **12.56.030 Subdivision, Commercial and Right-of-Way Development Inspection**

- A. The County Engineer will appoint such personnel as necessary to inspect the work on public roadway and drainage projects undertaken by the County and on all access permits, and they will exercise such authority as the County Engineer may delegate. On all other projects including all subdivision construction work and improvements on unopened County right-of-way, the applicant’s Engineer shall be responsible for all inspections outlined in this section.
- B. Failure to comply with the provisions of these Standards may result in stop work orders, removal of work accomplished, or other penalties as established by law.

### **12.56.040 Certification of Inspections and Testing**

For all road and drainage work, other than that performed by the County on County road and drainage projects and access permits, the County requires the applicant to engage the services of a professional engineer to document and certify all inspections and testing during the construction process. It is also the responsibility of the applicant and their engineer to provide the day-to-day inspection of such work, perform such inspections and testing of materials and their placement as may be required, and to certify all such inspections and testing including compliance with the approved plans and these Standards. A daily activity diary shall be kept by the applicant's engineer or his/her designee for all days that there is road or drainage work performed on the site. Copies of all test records, inspection records and the daily diary shall be furnished to the County Engineer on a weekly basis. At the time of each of the inspections as set forth in Chapter 12.56.050, the County Engineer or his/her designee will visit the project site to review the work related to the required inspection. Such site visits do not relieve the applicant, the contractor or the applicant's engineer of any responsibilities for performing all work in accordance with the approved plans and these Standards. The County Engineer or his/her designee may also visit the project site from time to time to monitor the overall progress of the project.

### **12.56.050 Inspection and Notification Requirements**

A. On all road construction by subdivision ordinance and work performed within the county right-of-way, inspection of the work will be done by the applicant's engineer or his/her designees under the overall authority of the County Engineer. Unless otherwise instructed by the County Engineer, the inspections will be made by and certified by the applicant's engineer as follows:

Inspection #1. Temporary sedimentation and erosion control in accordance with approved plans.

Inspection #2. Underground storm drainage, at the stage that trenching and placing of pipe are completed but prior to cover. If the scope of the project is such that there is more than one trenching, placing and covering is required, each such sequence shall be inspected separately.

Inspection #3. Underground utilities within the right-of-way, including sewers and storm drainage, shall be inspected during backfilling for compliance with the Standard Specifications and the requirements of the utility permit issued in conformance with the Douglas County "Accommodation of Utilities Within County Road Right-of-Way".

Inspection #4. General roadway at the stage that the subgrade has been completed. If the scope of the project is such that the subgrade is completed in stages and is ready for surfacing materials, each such stage shall be inspected separately.

Inspection #5. General roadway at the stage that the gravel base has been placed and compacted and the curbing, if required, has been formed. If the scope of the project is such that the gravel base is completed in stages and is ready for additional surfacing materials, and the curbing, if required, has been formed for that section, each such stage shall be inspected separately.

Inspection #6. General roadway at the stage that crushed surfacing top course has been placed and compacted.

Inspection #7. General roadway, at the beginning of paving.

Inspection #8. Overall roadway, final, after paving, monument inspection, cleaning of drainage systems, and all necessary clean up.

Structural Inspections. Structural inspections shall be at critical stages of foundation, placement and assembly of components and final completion and tests, as directed by the County Engineer.

- B. The County shall be notified not less than three (3) working days before construction is started. The applicant is responsible for scheduling a pre-construction conference with the County. Other jurisdictions, the applicant's engineer, the applicant's contractor, utility companies, subcontractors and other necessary parties to the project shall be present at the preconstruction conference.
- C. The applicant or the applicant's engineer shall notify the County Engineer's office at least one working day in advance of the beginning of each required inspection. Failure to comply with inspection requirements may necessitate appropriate or additional testing and certification as directed by the County Engineer. Costs of such testing and certification shall be borne by the contractor, and for subdivision roads, it shall be the developer. At the time that such action is directed by the County Engineer, no further work will be permitted on the road or subdivision until all tests have been completed and all corrections have been made to the satisfaction of the County Engineer.
- D. If the contractor believes that the inspection sequence indicated above does not fit the requirements of a particular project, he/she should make a request to the County Engineer in sufficient time to permit revision to the inspection schedule.

#### **12.56.060 Materials Sampling and Testing**

Materials sampling and testing shall be at the frequency and magnitude as set forth in the WSDOT Construction Manual. In the case of plat roads, testing and sampling shall be performed by a private testing laboratory. Certified test reports shall be furnished for all tests performed by private testing laboratories.

## **12.56.070 Traffic Control**

- A. The applicant or their contractor shall provide, place and maintain all Washington certified flaggers, flagger protective apparel, barricades, lights, standard signs, cones and other devices, equipment, and personnel necessary for the protection of the public and maintenance of traffic through the limits of the project at the applicant's expense. If the County finds an unsafe condition, the applicant, contractor, and applicant's engineer, if warranted, shall be notified and shall be required to correct the situation immediately. In some circumstances involving an immediate hazard to public safety, the County may make the appropriate corrections. The applicant shall be responsible for all costs incurred by the County.
- B. In addition to the requirements contained in the Standard Specifications, the following will be required:
1. The applicant shall maintain at least one-way traffic through the limits of construction at all times and shall open the roadway to two-way traffic during periods when actual work is not in progress.
  2. Access to side roads and private driveways shall be maintained at all times unless otherwise authorized by the County Engineer.
  3. The applicant or his/her contractor shall coordinate with the US Postal Service when construction requires mailboxes to be relocated or rearranged.
  4. When it becomes necessary to restrict access to private driveways for construction purposes, as approved by the County Engineer, the applicant shall inform affected residents at least 24 hours in advance and minimize inconvenience to residents of the area.
  5. When temporary road closures cannot be avoided and is approved by the County Engineer, the contractor shall post "To Be Closed (insert dates)" signs a minimum of five days prior to the closing. The types and locations of the signs shall be shown on a detour plan. A detour plan must be prepared and submitted to the County Engineer at least ten working days in advance of the proposed closure, and be approved prior to closing any County roadway. In addition, the contractor must notify, in writing, local fire, school, law enforcement authorities, postal service and any other affected persons as directed by the County Engineer at least five days prior to the closing.
  6. If the construction of a proposed development is determined by the County Engineer to require special routing of large trucks or heavy construction equipment to prevent impacts to surrounding roads, residences or business, the contractor shall be required to develop and use an approved haul route and enter into a haul road agreement as specified in DCC Title 12.28.150 establishing

restoration procedures and work to be performed by the contractor upon completion of the haul operation. When required, the haul route plan must be prepared and submitted to the County Engineer and approved prior to beginning or continuing construction. The haul route plan shall address routing, hours of operation, signing, flagging and daily maintenance. If the contractor's equipment or suppliers fail to use the designated haul route, the County Engineer may prohibit or limit further work on the development until such time as the requirements of the haul route are complied with.

#### **12.56.080 County Forces and County Contract Road Inspection**

Road construction performed by County forces or by contract for the County will be inspected under supervision of the County Engineer.

#### **12.56.090 Utilities**

- A. Existing utilities must be protected from damage by the contractor.
- B. Contractors shall utilize the One-Call Center service for the location of utilities a minimum of 48 hours in advance of any construction.
- C. The contractor shall obtain separate access or utility permits from the County before undertaking any construction work within the existing County right-of-way adjacent to the project.

#### **12.56.100 Posting of Site**

For all new major subdivision work and planned developments, the applicant shall post one or more signs showing the name of the subdivision or development, and the name or business name of the applicant, the applicant's engineer and the prime contractor along with a contact telephone number for each. The signs shall show the names and telephone numbers in suitably contrasting text not less than 2 inches in height. The signs shall be placed at the access point(s) from the County road to the new development and not more than 25 feet from the near edge of the County road.

#### **12.56.110 Final Acceptance**

Upon completion of all work, the applicant shall request acceptance by the Douglas County Engineer. As part of the acceptance process, the County Engineer shall review all documents including test reports, inspection certifications, daily diaries, and any notes made by the County Engineer or his/her designee during all site visits. The County Engineer, the applicant and the applicant's engineer shall conduct an on-site review of the project to ascertain the level of completeness of the project including cleanup. If the County Engineer is satisfied that the project has been completed in conformance with the approved plans, these Standards, and all other requirements that may have been imposed

by means of approved change orders, he/she shall provide the applicant with a written acceptance.

## ***Part 8 – Roadside Features***

### **12.57.010 Retaining Walls**

#### **A. General Design Requirements**

Retaining walls on public roads shall be designed and constructed to meet the minimum requirements of the AASHTO Bridge Specifications. Retaining walls with a height of four (4) feet or greater and all retaining walls with a surcharge shall be designed by a registered civil engineer licensed in the State of Washington, and shall be submitted by the applicant for approval by the County Engineer.

#### **B. Segmental or modular Walls (Mortarless concrete block walls) and rockery walls**

Mortarless concrete block walls shall be designed and constructed in accordance with the manufacturer's design and construction recommendations. For all such walls the manufacturer's design details and recommendations shall be furnished to the County Engineer for approval. Rockery walls shall be designed by a registered civil engineer licensed in the State of Washington.

### **12.57.020 Side Slopes**

- A.** Side slopes shall generally be constructed no steeper than 2 to 1 on both fill slopes and cut slope, however, side slopes on private roads may be as steep as 1-3/4 to 1. Steeper slopes may be approved by the County Engineer upon showing that steeper slopes, based on soils analysis, will be stable.
- B.** Side slopes shall be stabilized by grass sod, hydroseeding, or by planting or surfacing materials acceptable to the County Engineer.
- C.** Side slopes may also require flattening to accommodate utility placement.
- D.** Cut slopes may require terracing depending upon the total slope height and the nature of the material being cut. Cut slopes higher than 15 feet will require a soils analysis to determine if terracing will be required.

### **12.57.030 Mailboxes**

Mailbox type and location require approval of the Postal Service (USPS). Coordination with the local postmaster, early in the project design process, is important.

Individual and cluster mailboxes shall:

- A. Be approved by the USPS, and
- B. Have break-away designed support unless located a minimum of 18 inches behind a curb or located beyond the clear zone as set forth in Chapter 12.57.080, and
- C. Be constructed in accordance with WSDOT Standard Plan H-12, provided however, that the vertical supports shall be located a minimum of two (2) feet back of the ditch centerline on all ditch sections.

USPS requires installation of cluster box units (CBU) to serve four or more addresses. Specific requirements can be obtained from the local postmaster.

Where USPS requires Neighborhood Delivery and Collection Box Units (NDCBU), they shall be located as required by USPS.

Turnouts for mail delivery vehicles shall be installed to serve CBU's and NDCBU's located along arterial or collector roads, or any road with a posted speed of 35 mph or above.

#### **12.57.040 Survey Monuments**

1. All existing survey control monuments which are disturbed, lost, or destroyed during construction shall be replaced by a registered surveyor at the expense of the developer. All permits to remove, destroy or replace monuments shall be filed with the State Department of Natural Resources pursuant to Washington Administrative Code.
2. Any "aliquot corner" (section corner, quarter corner, etc.), as described in the Public Land Survey System, shall be monumented per Washington State Statutes and utilize the monumentation standard shown in Figure 8-2. If such a corner falls within concrete or asphalt, a monument case and cover as shown in Figure 8-3 shall be installed to protect and provide access to said corner.
3. Survey control monuments shall be placed or replaced in accordance with recognized good practice of land surveying, and in conformance with all applicable state and local regulations.
4. Survey monuments shall be placed at all exterior boundary corners of plats and on all lot corners and shall consist of a one- inch galvanized pipe or one-half inch reinforcing bar with identifying cap attached. Pipe or reinforcing bar must be a minimum of two (2) feet in length.

5. Survey monuments are required at all road intersections, points of horizontal curvature (PC's), points of horizontal tangency (PT's), centers of cul-de-sacs and other appropriate locations as determined necessary by the County. Monuments at PC's and PT's may be eliminated and replaced with a monument at the Point of Intersection (PI), if the PI falls within the paved roadway surface. See Figure 8-1 for roadway survey monuments. No monumentation is required for unpaved roads except at the intersection with a paved road.
6. All paved road monumentation shall use county type monuments and cases, available through private distributors or Douglas County Department of Transportation and Land Services at the applicant's expense. A monument as required above shall be placed in paved roads at all points of curves, points of tangent, intersections and as needed for inter-visibility and at the intersection of road centerlines and at the center of cul-de-sacs within plat boundaries. No monumentation is required for unpaved roads except at the intersection with a paved road.
7. A signed and sealed statement from the applicant's land surveyor that all monuments and corners indicated on the subdivision plat have been set and are in good condition will be required before a final approval of the road can be made.
8. Record of the monumentation shall be made in accordance with the Survey Recording Act.

#### **12.57.050 Barricades**

Temporary and permanent barricades shall be installed by the applicant or their contractor and shall conform to the standards described in Section 6C-8 of the Manual on Uniform Traffic Control Devices (MUTCD) and these standards.

- A. Type I or Type II barricades may be used when traffic is maintained through the area being constructed or reconstructed. They may be used singly or in groups to mark a specific hazard or they may be used in a series for channelizing traffic.
- B. Type III barricades may be used when roadways and/or proposed future roadways are closed to traffic. Type III barricades may extend completely across a roadway and its shoulder (as a fence) or from curb to curb. Where provision must be made for access of equipment and authorized vehicles, the Type III barricades may be provided with movable sections that can be closed when work is not in progress, or with indirect openings that will discourage public entry. Where job site access is provided through Type III barricades, the developer/contractor shall assure proper closure at the end of each working day.

- C. In the general case, Type III permanent barricades shall be installed to close arterial roadways or other through streets hazardous to traffic. They shall also be used to close off lanes where tapers are not sufficiently delineated.
- D. Type I barricades may be used at the end of a local access street terminating abruptly without a cul-de-sac bulb. Each such barricade shall be used together with an end-of-road marker.
- E. Signs may be erected on barricades, particularly those of fixed type. The ROAD CLOSED and detour arrow signs, and the large arrow warning signs can be mounted effectively on or above the barricade that closes the roadway.
- F. For nighttime use, it is desirable to add flashing warning lights when barricades are used singly and steady-burn lights when barricades are used in series for channelization.

#### **12.57.060 Bollards**

When necessary to deny motor vehicle access to an easement, tract or trail, except for maintenance or emergency vehicles, the point of access shall be closed by a line of bollards. These shall include one or more fixed bollards on each side of the traveled way and removable, locking bollards across the traveled way. Spacing shall provide one bollard on centerline of the trail and the other bollards spaced at minimum of 50 inches on center on trails 10 feet wide or less. Spacing of 60 inches on center on trails wider than 10 feet. Bollard design shall be in accordance with WSDOT Standard Plans H-13 or H-13a or other design acceptable to the Engineer. No fire apparatus access roads shall be blocked in this manner without concurrence of the Fire Marshall. Bollards shall be located at least 10 feet laterally from the paved edge of roadway.

#### **12.57.070 Guardrail**

- A. Evaluation of embankments for guardrail installations shall be in accordance with Chapter 710 of the WSDOT Design Manual or the AASHTO Roadside Design Guide.
- B. Guardrail installations shall conform to WSDOT Standard Plan C-1, Beam Guardrail Type 1 and C-2 Guardrail Placement. End anchors shall conform to WSDOT Standard Plan C-6, Beam Guardrail Anchor Type 1.

#### **12.57.080 Roadside Obstacles**

- A. WSDOT Clear Zone distances as described in Chapter 700 of the WSDOT Design Manual, shall be used as a guide for evaluation and placement of roadside features within the County right-of-way.

- B. In general, existing or new roadside features which could present a hazard to the public should be placed outside of clear zone areas unless justified to the County Engineer's satisfaction by suitable engineering studies considering traffic safety, or where shielded by a barrier, placed in an area normally inaccessible to vehicles or utilize a break-away design.
- C. Locations of poles and other above-ground appurtenances shall be compatible with driveways, intersections and other roadway features (i.e., they shall not interfere with sight distance, roadway signing, traffic signals, culverts, etc.). To the greatest extent possible, installation of poles and other above ground appurtenances will not be permitted in sidewalks or walkways.
- D. Costs of relocating poles or obstacles to achieve these standards are the responsibility of the developer. This is not intended to prevent the developer from making financial arrangements with the appropriate utility or other owner of the obstacle to accomplish removal of the pole or obstacle.

#### **12.57.090 Medians**

Where required for traffic control or landscape planters, medians shall be in addition to, not part of the specified roadway width. Medians shall be designed so as not to limit turning radii or sight distance at intersections. Median edges may be either standard curb or shoulder and ditch. Medians with shoulder and ditch edges shall be a minimum four (4) feet in width. Medians may be grassed, landscaped, or surfaced with aggregate or pavement. Curbed medians shall require an additional two (2) feet of roadway width on each side to accommodate vehicle shy distance.

#### **12.58.100 Roadway Illumination**

Roadway illumination is not normally required as part of a project unless a project road falls within the urban growth area surrounding a city that requires street lighting. If illumination is required, the following provisions shall apply:

- A. Street lighting system designs are to be prepared by a licensed engineer experienced with lighting design. Calculations should include illuminance spacing, illumination levels, line losses, power sources and other necessary details for the electrical and physical installation of the street lighting system.

B. The following illumination levels shall be met based on the urban roadway classification:

Urban Classification	Horizontal Foot Candles
Principal Arterials	1.5 FC
Minor and Collector Arterials	1.0 FC
Local Commercial/Industrial	1.0 FC
Local Access	At intersections or street ends

C. Other Considerations

1. All street lights shall be on two hundred forty (240) volt, single phase systems. The exact location of the power source should be indicated together with the remaining capacity of that circuit. System continuity and extension should be considered.
2. Contractor cabinets equipped with electrical meters, time clocks, circuit breakers, and other required components are required on commercial installations of five or more street lights.
3. All street lighting, wiring, and service connectors shall be located underground except in residential areas where existing power distribution poles exist.
4. Particular attention shall be given to locating luminaries near intersections, at all street ends and at pedestrian, bicycle, and/or equestrian crossings.
5. Mounting height shall be a maximum of thirty (30) feet for all luminaries.
6. In lieu of a street light, at the end of the cul-de-sac, permanent driveway pedestal lighting provided by all lots accessing the cul-de-sac may be substituted, provided that it is noted on the face of the plat.

**12.58.110 Landscaping**

Landscaping requirements including landscaping plans are contained in DCC 20.40 “Landscaping Standards”.

### **12.58.120 Roadway Permanent Signing and Pavement Markings**

- A. Unless otherwise approved by the County Engineer, the County shall install and be reimbursed by the developer for the installation of all necessary street name signs, warning signs and regulatory signs. The County will assume maintenance of all signs after installation, except for signs on private roads. All signs must be installed prior to issuance of any building permits and opening of roads for use. All signing shall be in accordance with MUTCD.
  
- B. Where required by the approved signing and striping plan, roadway striping, buttoning or other traffic delineators shall be installed by the applicant's contractor in accordance with the approved plans and the MUTCD and be in place prior to opening the roads for use. Before any pavement marking work takes place, the applicant shall contact the County Engineer. An on-site meeting may be required to review the work and method of construction.

## ***Part 9 – Primitive Roads - Unopened County Right of Way***

### **12.59.010 General**

Primitive roads or unopened public road rights-of-way not developed to the minimum design standard are not considered adequate for new construction and development activities. These development activities shall require improvements to the design as detailed herein and in previous sections. Costs will be borne by the applicant proposing construction or development.

Throughout the County there are portions of Primitive roads and unopened public road rights-of-way that have not been maintained, improved or officially opened and established as county roads by the County or vacated by the County. There may be individuals or corporations wishing to utilize primitive roads or unopened County right-of-way for access to private property.

### **12.59.020 Permits Required**

A permit is required to improve county right-of-way for road purposes. A right of way permit application, on forms provided by the County Engineer, shall be approved prior to the improvement of a primitive road and or unopened right-of-way.

#### **A. Right of Way Permit**

1. A Right-of-Way permit shall be required for opening or improving a public right-of-way. Improvements meeting the road standards as set forth in Chapter 12.53 shall be constructed following the approval of the application and plans by the County Engineer. Roads meeting the private road standards shall not be eligible for designation as a county public road.
2. Requirements
  - a. The roadway section shall meet the requirements for private roads as set forth in Chapter 12.53 of these Standards. If more than 16 lots, parcels or tracts are to be served, the road must be designed to public road standards. If the width of the unopened right-of way and the terrain prevent the proposed road from meeting the public road standards, the permit shall be denied.
  - b. If the road is to be proposed for establishment as a county road, the applicant shall pay for the purchase and installation of all signing required by the County. Subsequent to the installation and establishment as a county road, signing will be maintained by the County.

- c. The County Engineer shall review for approval plans of the required improvements necessary for designation as a public road. Upon completion of necessary improvement, the County Engineer shall indicate approval on the permit application and make the appropriate notification to the Board of County Commissioners. The Board of County Commissioner shall conduct a public hearing and declare the road established by resolution for public purpose. Upon establishment by the Board of County Commissioners, they will enter the appropriate information into the official County records.
- d. The permit application shall include:
  - (1). A legal description of the lot(s), tract(s) or parcel(s) to be served by the permit.
  - (2). A statement regarding the purpose of access to subject lot(s), tract(s) or parcel(s).
  - (3). Proof of appropriate subdivision ordinance approval or, if exempt from platting, an assessor's map showing the parcels served.
  - (4). If there is no official road name, three choices for road name shall be submitted for approval at the time of permit application submittal.
  - (5). Two (2) sets of engineered roadway and drainage plans for the planned improvements as per Douglas County Road Standards, including a vicinity map.

**B. Additional Requirements**

- 1. Detailed engineering and drainage plans will be required by the County Engineer. Cost for the development and preparation of such plans shall be borne by the permit applicant. When required, such plans shall be prepared in accordance with the requirements of these Standards.
- 2. The applicant shall cause the right-of-way to be surveyed by a licensed land surveyor at the applicant's expense to adequately define the limits of the unopened right-of-way. Such survey shall be recorded in accordance with the Survey Recording Act.
- 3. An applicant shall be required to deed additional right-of way across property under his/her authority when necessary to fulfill the minimum road right of way as required by these Standards.

4. An applicant shall provide certification that all owners of the property abutting on each side of the unopened right-of-way have been provided written notification of the permit application. Any objections of such property owners shall be stated along with the manner in which the applicant proposed to resolve said objections.
5. Restoration sureties may be required by the County Engineer in the manner provided for in Chapter 12.51.110 of these Standards.

# RURAL AREA ROADWAY DESIGN STANDARDS

## ROADWAY CLASSIFICATION: PRIVATE ROAD 20-YR PROJECTED AVERAGE DAILY TRAFFIC (AADT): LESS THAN 160

For AADT greater than 160, see Figures 3-2 and 3-3 for requirements

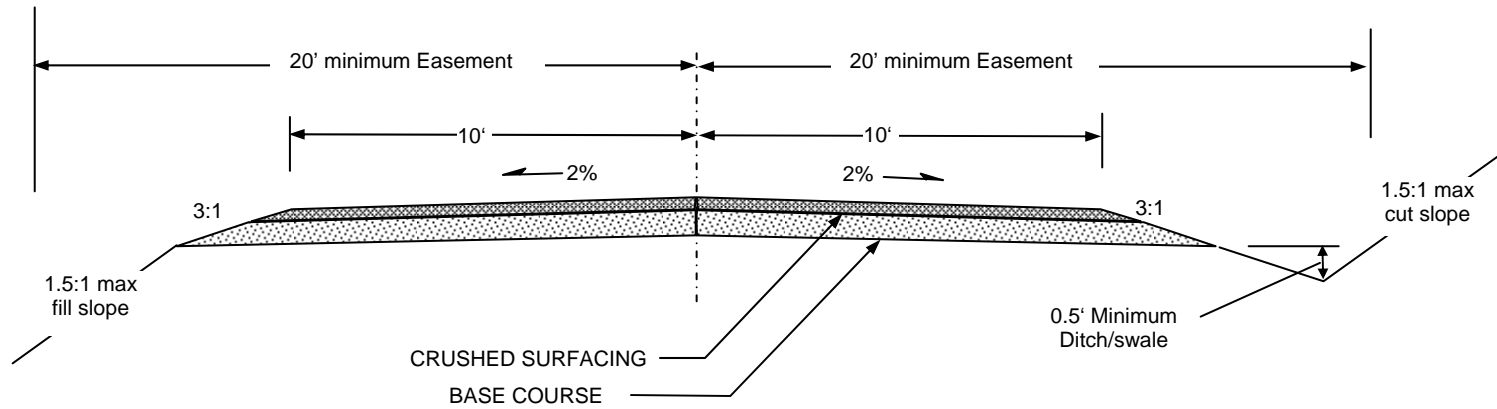

DESIGN SPEED (MPH)	Flat=40; Rolling=30; Mountainous=20
MAXIMUM ROAD GRADE (Percent)	Flat=7%; Rolling=9%; Mountainous=12%
MINIMUM ROAD GRADE (Percent)	0.5%
MINIMUM ROADWAY WIDTH (Ft)	20 ft.
MINIMUM SURFACING WIDTH (Ft)	20 ft.
MINIMUM DESIGN LOAD	HS 20-44
MINIMUM EASEMENT WIDTH (Ft)	40 ft.
MINIMUM REQUIRED SURFACING:	
CRUSHED SURFACING TOP COURSE	2" compacted depth
CRUSHED SURFACING BASE COURSE*	10" compacted depth*
VERTICAL CLEARANCE	16.5 ft.

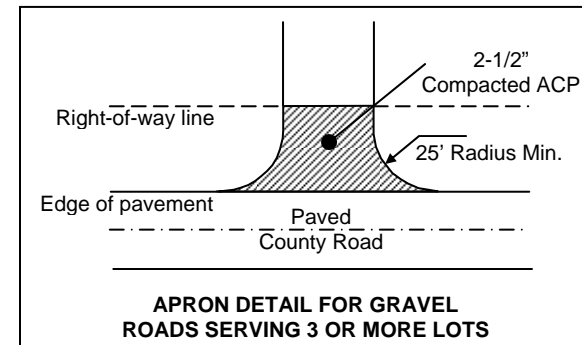

PrivateRoad.doc

**DOUGLAS COUNTY  
DEPARTMENT OF  
TRANSPORTATION &  
LAND SERVICES**

REVISIONS	DATE

**ROADWAY  
STANDARDS**

**PRIVATE ROADWAY SECTION**

**FIGURE 3 - 1**

7/21/04

# RURAL AREA ROADWAY DESIGN STANDARDS

ROADWAY CLASSIFICATION: LOCAL ACCESS  
 20-YR PROJECTED AVERAGE DAILY TRAFFIC (AADT): Under 400

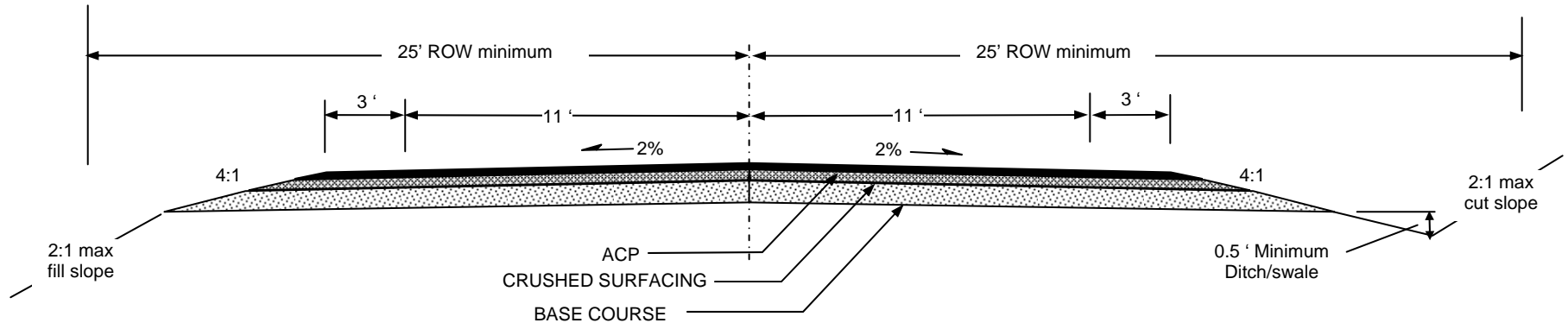

\* BST Class A may be used in place of ACP however, total surface depth may not be less than 12 inches.

DESIGN SPEED (MPH)	Flat=50; Rolling=40; Mountainous=20
MAXIMUM ROAD GRADE (Percent)	Flat=6%; Rolling=8%; Mountainous=12%
MINIMUM ROAD GRADE (Percent)	0.5%
MINIMUM ROADWAY WIDTH (Ft)	28 ft.
MINIMUM SURFACING WIDTH (Ft)	28 ft.
MINIMUM DESIGN LOAD	HS 20-44
MINIMUM RIGHT-OF-WAY WIDTH (Ft)	50 ft.
MINIMUM REQUIRED SURFACING:	
ACP or BST	ACP = 2-1/2" compacted depth *
CRUSHED SURFACING TOP COURSE	4" compacted depth
CRUSHED SURFACING BASE COURSE	8" compacted depth
VERTICAL CLEARANCE	16.5 ft.

LocalAccessUnder400.doc

**DOUGLAS COUNTY  
 DEPARTMENT OF  
 TRANSPORTATION &  
 LAND SERVICES**

REVISIONS	DATE

**ROADWAY  
 STANDARDS**

**RURAL LOCAL ACCESS  
 ROADWAY SECTION  
 AADT under 400  
 FIGURE 3 - 2**

7/21/04

# RURAL AREA ROADWAY DESIGN STANDARDS

ROADWAY CLASSIFICATION: LOCAL ACCESS  
 20-YR PROJECTED AVERAGE DAILY TRAFFIC (AADT): OVER 400

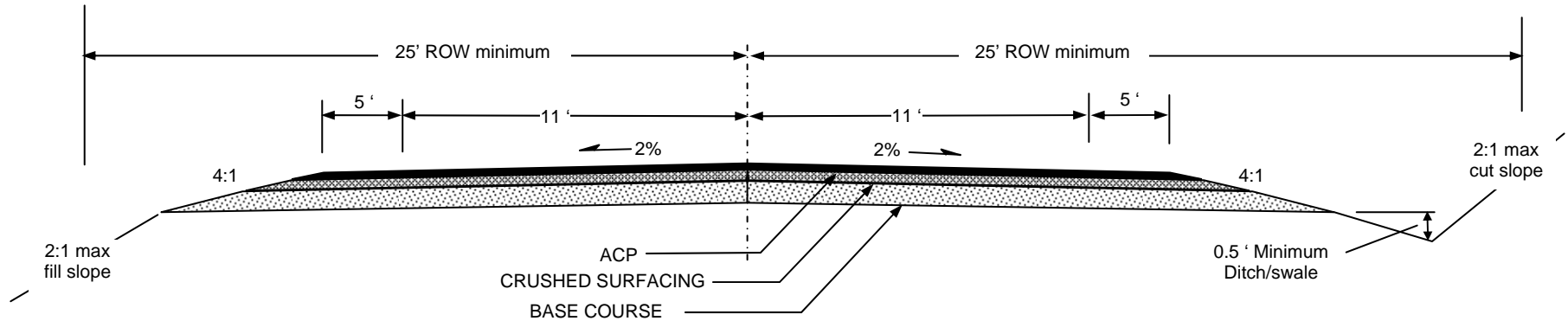

DESIGN SPEED (MPH)	Flat=50; Rolling=40; Mountainous=30
MAXIMUM ROAD GRADE (Percent)	Flat=6%; Rolling=8%; Mountainous=10%
MINIMUM ROAD GRADE (Percent)	0.5%
MINIMUM ROADWAY WIDTH (Ft)	32 ft.
MINIMUM SURFACING WIDTH (Ft)	32 ft.
MINIMUM DESIGN LOAD	HS 20-44
MINIMUM RIGHT-OF-WAY WIDTH (Ft)	50 ft.
MINIMUM REQUIRED SURFACING:	
ACP	ACP = 2-1/2" compacted depth
CRUSHED SURFACING TOP COURSE	4" compacted depth
CRUSHED SURFACING BASE COURSE	8" compacted depth
VERTICAL CLEARANCE	16.5 ft.

LocalAccessOver400.doc

**DOUGLAS COUNTY  
 DEPARTMENT OF  
 TRANSPORTATION &  
 LAND SERVICES**

REVISIONS	DATE

**ROADWAY  
 STANDARDS**

**RURAL LOCAL ACCESS  
 ROADWAY SECTION  
 AADT OVER 400  
 FIGURE 3 - 3**

7/21/04

# RURAL AREA ROADWAY DESIGN STANDARDS

ROADWAY CLASSIFICATION: MAJOR & MINOR COLLECTORS  
 20-YR PROJECTED AVERAGE DAILY TRAFFIC (AADT): UNDER 400

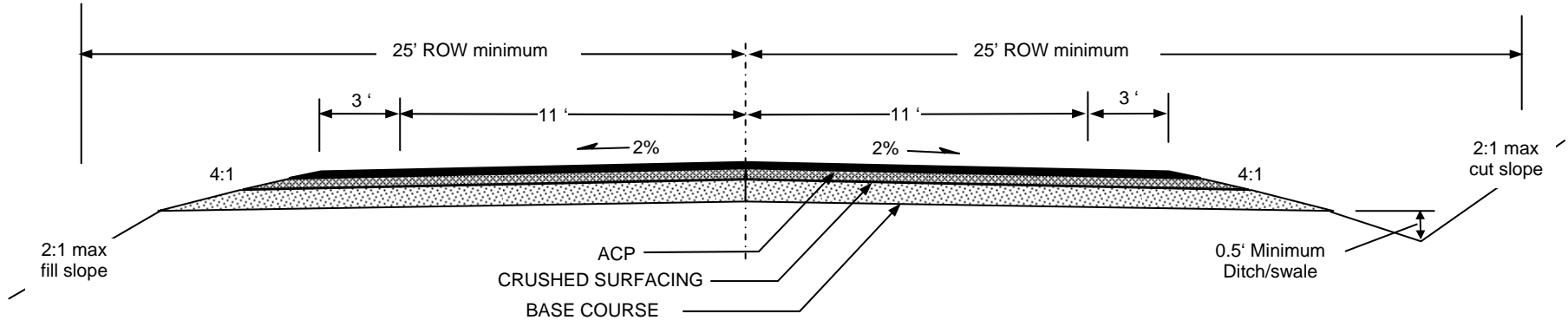

DESIGN SPEED (MPH)	Flat=50; Rolling=40; Mountainous=30
MAXIMUM ROAD GRADE (Percent)	Flat=6%; Rolling=8%; Mountainous=10%
MINIMUM ROAD GRADE (Percent)	0.5%
MINIMUM ROADWAY WIDTH (Ft)	28 ft.
MINIMUM SURFACING WIDTH (Ft)	28 ft.
MINIMUM DESIGN LOAD	HS 20-44
MINIMUM RIGHT-OF-WAY WIDTH (Ft)	50 ft.
MINIMUM REQUIRED SURFACING:	
ACP	ACP = 2-1/2" compacted depth
CRUSHED SURFACING TOP COURSE	4" compacted depth
CRUSHED SURFACING BASE COURSE	8" compacted depth
VERTICAL CLEARANCE	16.5 ft.

CollectorUnder401.doc

**DOUGLAS COUNTY  
 DEPARTMENT OF  
 TRANSPORTATION &  
 LAND SERVICES**

REVISIONS	DATE

**ROADWAY  
 STANDARDS**

**RURAL MAJOR & MINOR  
 COLLECTOR ROADWAY  
 SECTION - AADT UNDER 400  
 FIGURE 3 - 4**

7/21/04

# RURAL AREA ROADWAY DESIGN STANDARDS

ROADWAY CLASSIFICATION: MAJOR & MINOR COLLECTORS and ARTERIALS  
 20-YR PROJECTED AVERAGE DAILY TRAFFIC (AADT): 401 - 2000

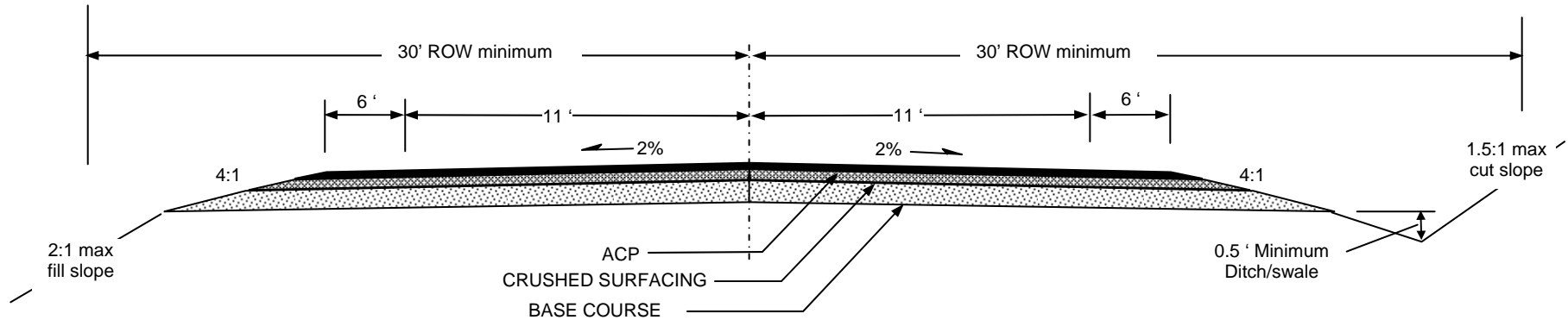

DESIGN SPEED (MPH)	Flat=60; Rolling=50; Mountainous=40
MAXIMUM ROAD GRADE (Percent)	Flat=6%; Rolling=8%; Mountainous=10%
MINIMUM ROAD GRADE (Percent)	0.5%
MINIMUM ROADWAY WIDTH (Ft)	34 ft.
MINIMUM SURFACING WIDTH (Ft)	34 ft.
MINIMUM DESIGN LOAD	HS 20-44
MINIMUM RIGHT-OF-WAY WIDTH (Ft)	60 ft.
MINIMUM REQUIRED SURFACING:	
ACP	ACP = 3" compacted depth
CRUSHED SURFACING TOP COURSE	4" compacted depth
CRUSHED SURFACING BASE COURSE	10" compacted depth
VERTICAL CLEARANCE	16.5 ft.

Collector401-2000.doc

**DOUGLAS COUNTY  
 DEPARTMENT OF  
 TRANSPORTATION &  
 LAND SERVICES**

REVISIONS	DATE

**ROADWAY  
 STANDARDS**

**RURAL MAJOR & MINOR  
 COLLECTOR and ARTERIAL  
 ROADWAY SECTION  
 AADT 401 - 2000  
 FIGURE 3 - 5**

7/21/04

# RURAL AREA ROADWAY DESIGN STANDARDS

ROADWAY CLASSIFICATION: MAJOR & MINOR COLLECTORS and ARTERIALS  
 20-YR PROJECTED AVERAGE DAILY TRAFFIC (AADT): OVER 2000

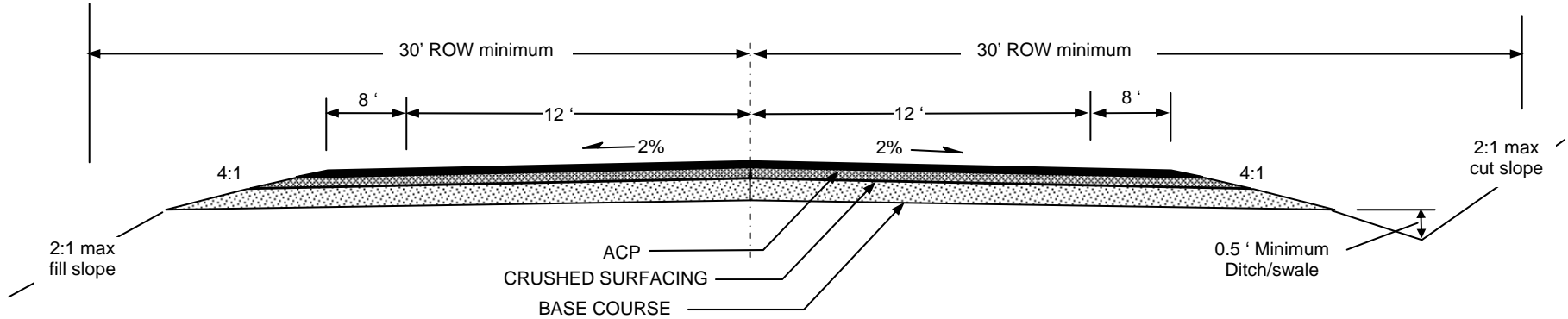

DESIGN SPEED (MPH)	Flat=60; Rolling=50; Mountainous=40
MAXIMUM ROAD GRADE (Percent)	Flat=6%; Rolling=7%; Mountainous=10%
MINIMUM ROAD GRADE (Percent)	0.5%
MINIMUM ROADWAY WIDTH (Ft)	40 ft.
MINIMUM SURFACING WIDTH (Ft)	40 ft.
MINIMUM DESIGN LOAD	HS 20-44
MINIMUM RIGHT-OF-WAY WIDTH (Ft)	60 ft.
MINIMUM REQUIRED SURFACING:	
ACP	ACP = 3" compacted depth
CRUSHED SURFACING TOP COURSE	4" compacted depth
CRUSHED SURFACING BASE COURSE	10" compacted depth
VERTICAL CLEARANCE	16.5 ft.

CollectorOver2000.doc

**DOUGLAS COUNTY  
 DEPARTMENT OF  
 TRANSPORTATION &  
 LAND SERVICES**

REVISIONS	DATE

**ROADWAY  
 STANDARDS**

**RURAL MAJOR & MINOR  
 COLLECTOR AND ARTERIAL  
 ROADWAY SECTION  
 AADT OVER 2000  
 FIGURE 3 - 6**

7/21/04

# URBAN AREA ROADWAY DESIGN STANDARDS

ROADWAY CLASSIFICATION: URBAN LOCAL ACCESS  
 20-YR PROJECTED AVERAGE DAILY TRAFFIC (AADT): UNDER 200

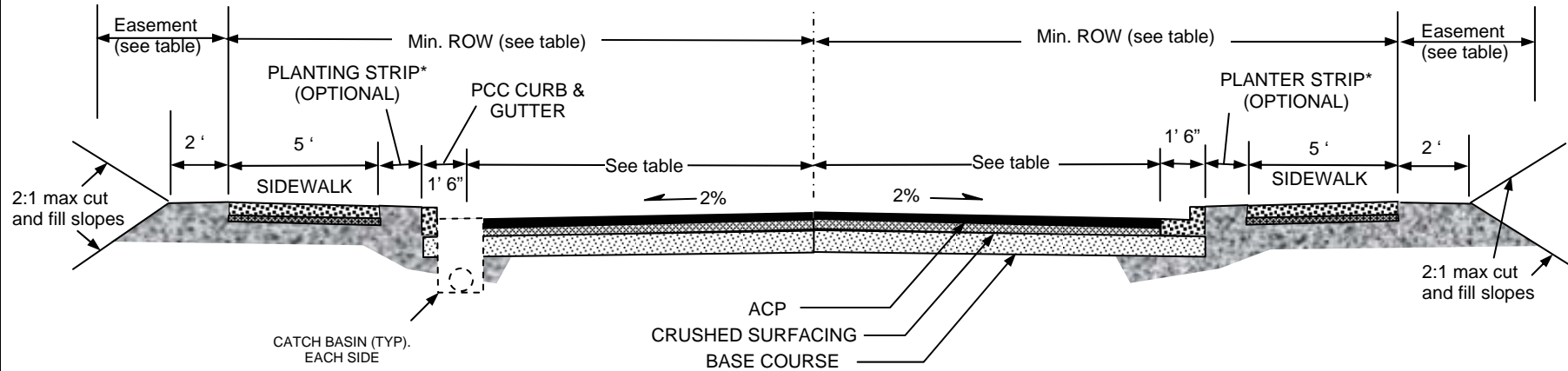

**NOTES:**

Sidewalks shall have a 2% cross slope toward the roadway

Minimum surfacing width includes PCC curb & gutter

Additional ROW will be required if planting strips are included

	No Parking	Parking one side	Parking both sides
DESIGN SPEED (MPH)	25 MPH		
MAXIMUM ROAD GRADE (Percent)	12%		
MINIMUM ROAD GRADE (Percent)	0.5%		
MINIMUM ROADWAY WIDTH (Ft)	28 ft (2-12-12-2)	28 ft (7-10-10-1)	32 ft (7-9-9-7)
MINIMUM SURFACING WIDTH (Ft)	28 ft	28 ft	32 ft
MINIMUM DESIGN LOAD	HS 20-44		
MINIMUM RIGHT-OF-WAY WIDTH (Ft)	45 ft	50 ft	50 ft
MINIMUM REQUIRED SURFACING:			
ACP	ACP = 2-1/2" compacted depth		
CRUSHED SURFACING TOP COURSE	4" compacted depth		
CRUSHED SURFACING BASE COURSE	8" compacted depth		
MINIMUM EASEMENT WIDTH	7.5 ft	5.0 ft	5.0 ft
VERTICAL CLEARANCE	16.5 ft.		

UrbLocAccess.doc

**DOUGLAS COUNTY  
 DEPARTMENT OF  
 TRANSPORTATION &  
 LAND SERVICES**

REVISIONS	DATE

**ROADWAY  
 STANDARDS**

**URBAN LOCAL ACCESS  
 ROADWAY SECTION  
 AADT Under 200  
 FIGURE 3 – 7a**

7/21/04

# URBAN AREA ROADWAY DESIGN STANDARDS

ROADWAY CLASSIFICATION: URBAN LOCAL ACCESS  
 20-YR PROJECTED AVERAGE DAILY TRAFFIC (AADT): 200 AND OVER

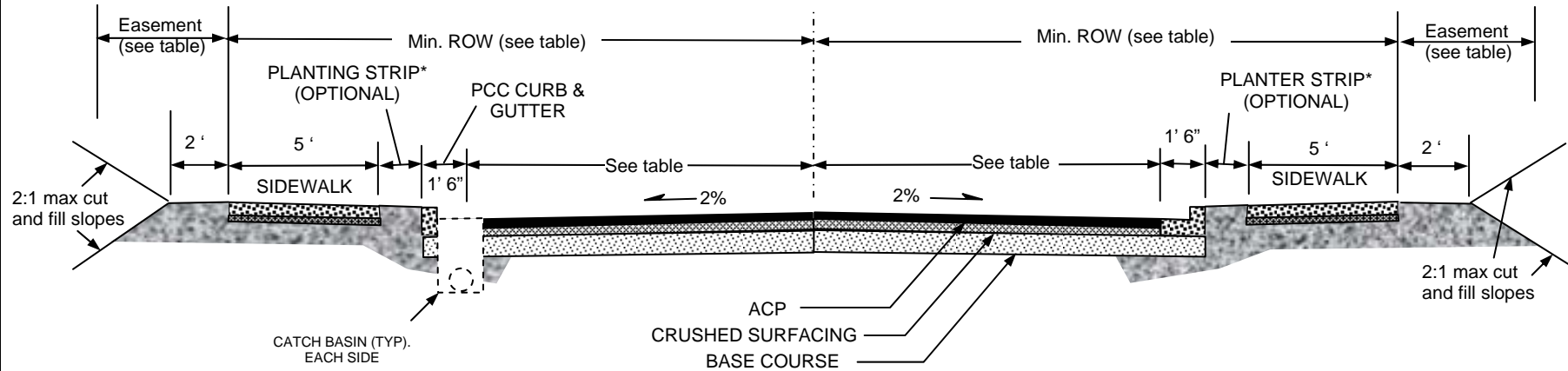

**NOTES:**

Sidewalks shall have a 2% cross slope toward the roadway

Minimum surfacing width includes PCC curb & gutter

Additional ROW will be required if planting strips are included

	No Parking	Parking one side	Parking both sides
DESIGN SPEED (MPH)	25 MPH		
MAXIMUM ROAD GRADE (Percent)	12 %		
MINIMUM ROAD GRADE (Percent)	0.5 %		
MINIMUM ROADWAY WIDTH (Ft)	28 ft (2-12-12-2)	32 ft (8-11-11-2)	36 ft (7-11-11-7)
MINIMUM SURFACING WIDTH (Ft)	28 ft	32 ft	36 ft
MINIMUM DESIGN LOAD	HS 20-44		
MINIMUM RIGHT-OF-WAY WIDTH (Ft)	45 ft	50 ft	50 ft
MINIMUM REQUIRED SURFACING:			
ACP	ACP = 2-1/2" compacted depth		
CRUSHED SURFACING TOP COURSE	4" compacted depth		
CRUSHED SURFACING BASE COURSE	8" compacted depth		
MINIMUM EASEMENT WIDTH	7.5 ft	5.0 ft	5.0 ft
VERTICAL CLEARANCE	16.5 ft.		

UrbLocAccess.doc

**DOUGLAS COUNTY  
 DEPARTMENT OF  
 TRANSPORTATION &  
 LAND SERVICES**

REVISIONS	DATE

**ROADWAY  
 STANDARDS**

**URBAN LOCAL ACCESS  
 ROADWAY SECTION  
 AADT 200 and over  
 FIGURE 3 – 7b**

7/21/04

# URBAN AREA ROADWAY DESIGN STANDARDS

## ROADWAY CLASSIFICATION: COLLECTOR and ARTERIAL 2 Through Lanes + 2-Way Left Turn + Bicycle Lane Each Side + No Parking

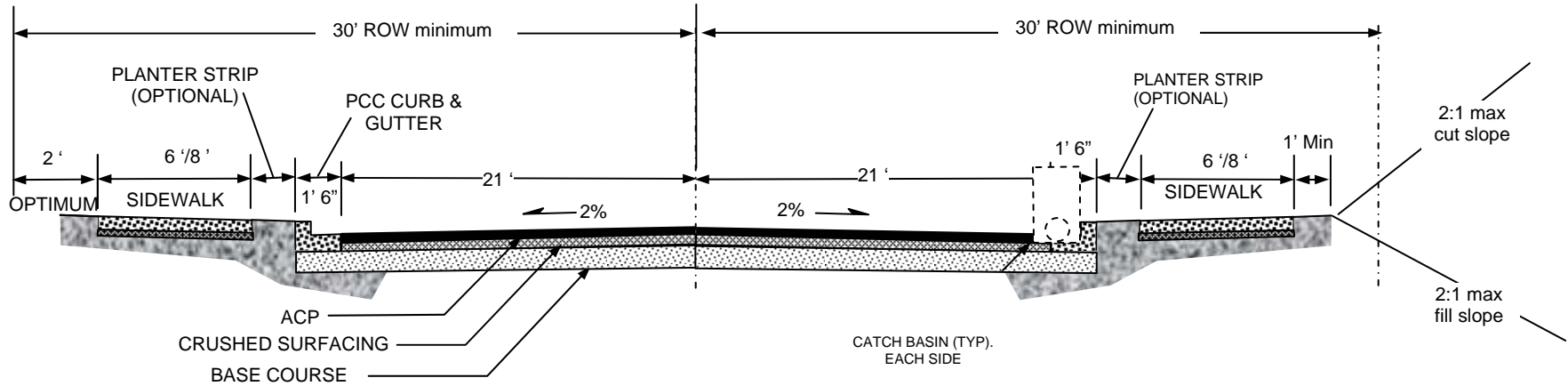

### NOTES

Sidewalks shall have a 2% cross slope toward the roadway

Sidewalks adjacent to PCC curb & gutter may include the top of curb in the total minimum sidewalk width.

Sidewalks adjacent to the PCC curb & gutter shall be 8 feet in width.

DESIGN SPEED (MPH)	25 to 35 MPH; 45 to 55 for arterials
MAXIMUM ROAD GRADE (Percent)	10%; 8% for arterials
MINIMUM ROAD GRADE (Percent)	0.5%
MINIMUM ROADWAY WIDTH (Ft) *	44 ft. curb section; 48 ft. for arterials
MINIMUM SURFACING WIDTH (Ft)	44 ft. curb section; 48 ft. for arterials
MINIMUM DESIGN LOAD	HS 20-44
MINIMUM RIGHT-OF-WAY WIDTH (Ft)*	60' collector; 70' arterial
MINIMUM REQUIRED SURFACING:	
ACP	ACP = 3" compacted depth
CRUSHED SURFACING TOP COURSE	4" compacted depth
CRUSHED SURFACING BASE COURSE	8" compacted depth
VERTICAL CLEARANCE	16.5 ft.

\* Additional roadway width and right of way width may be required for channelizations, additional thru lanes, parking and medians.

UrbCollector.doc

**DOUGLAS COUNTY  
DEPARTMENT OF  
TRANSPORTATION &  
LAND SERVICES**

REVISIONS	DATE

**ROADWAY  
STANDARDS**

**URBAN COLLECTOR &  
ARTERIAL  
ROADWAY SECTION**

**FIGURE 3 - 8**

7/21/04

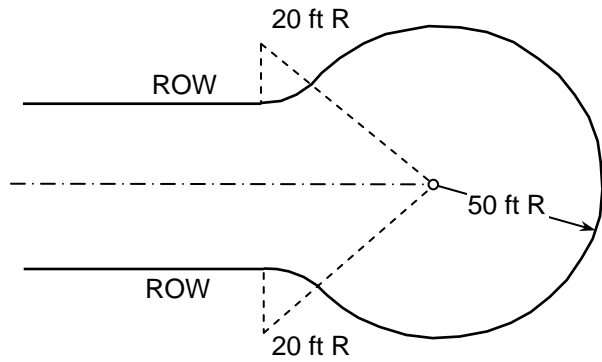

**STANDARD**

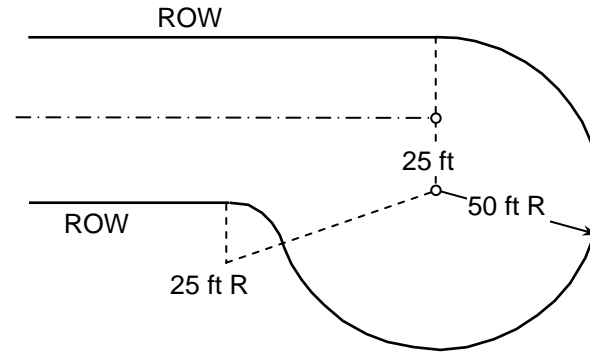

**OFF-SET**

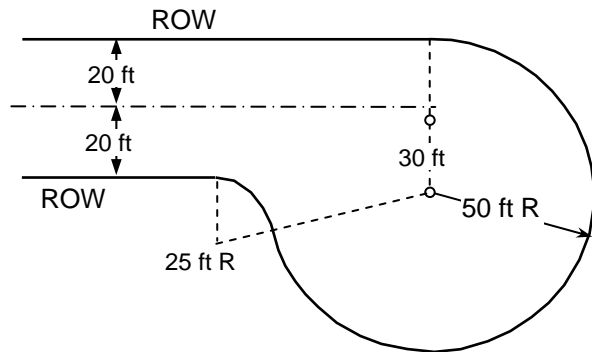

**PRIVATE – Under 160 AADT**

**CUL – DE – SAC's**

See Roadway Section drawings for Road Section and Right of Way requirements.

Cul-de-sac.doc

**DOUGLAS COUNTY  
DEPARTMENT OF  
TRANSPORTATION &  
LAND SERVICES**

REVISIONS	DATE

**ROADWAY  
STANDARDS**

**CUL-DE-SAC DETAILS**

**FIGURE 3-9**

7/21/04

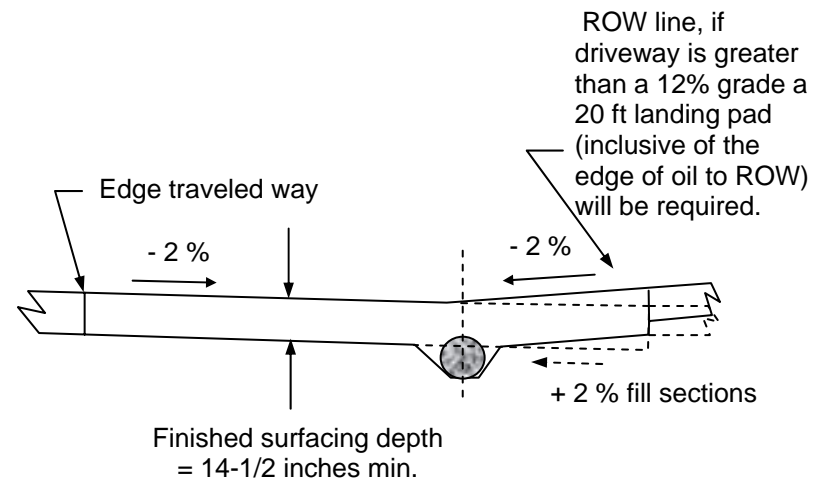
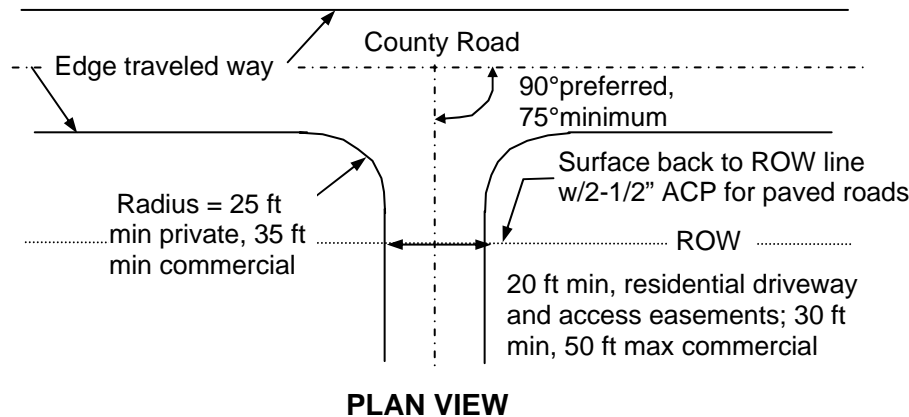
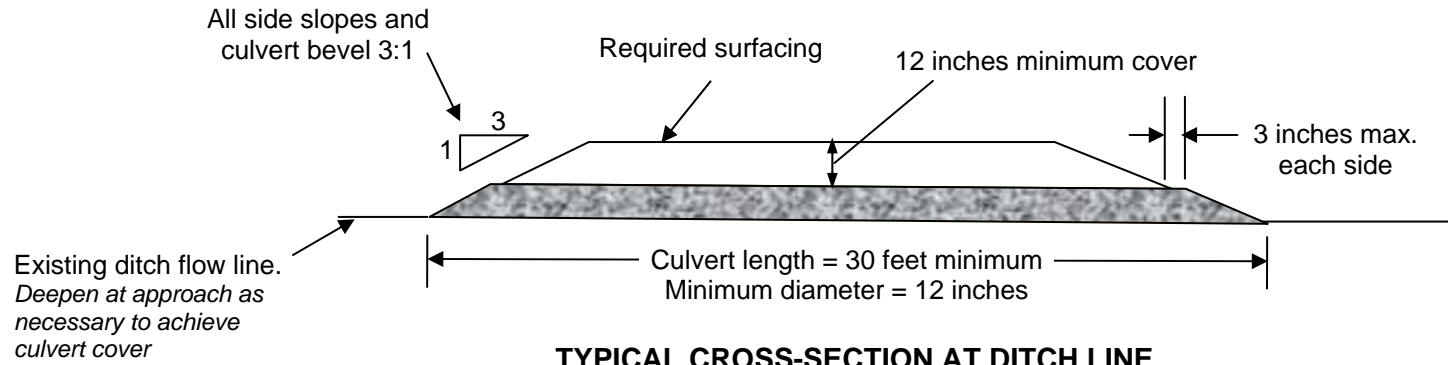

Note: This drawing is for driveways and accesses primarily used by passenger cars and light trucks. Additional modifications such as deceleration and acceleration tapers and increased turning radiuses may be required to accommodate larger vehicles.

Accesses.doc

**DOUGLAS COUNTY  
DEPARTMENT OF  
TRANSPORTATION &  
LAND SERVICES**

REVISIONS	DATE

**ROADWAY  
STANDARDS**

**DRIVEWAYS AND  
ACCESS EASEMENT**

**FIGURE 4 - 1**

7/21/04

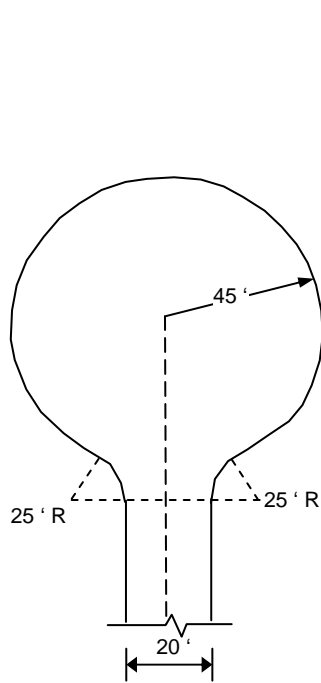

TYPE 1

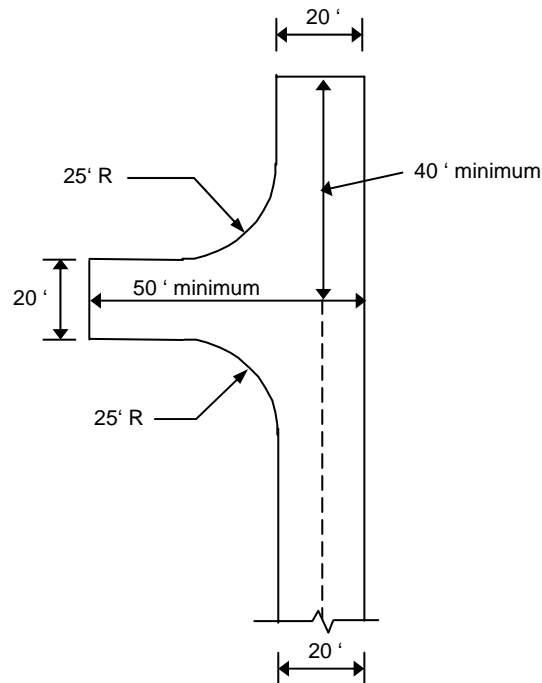

TYPE 2

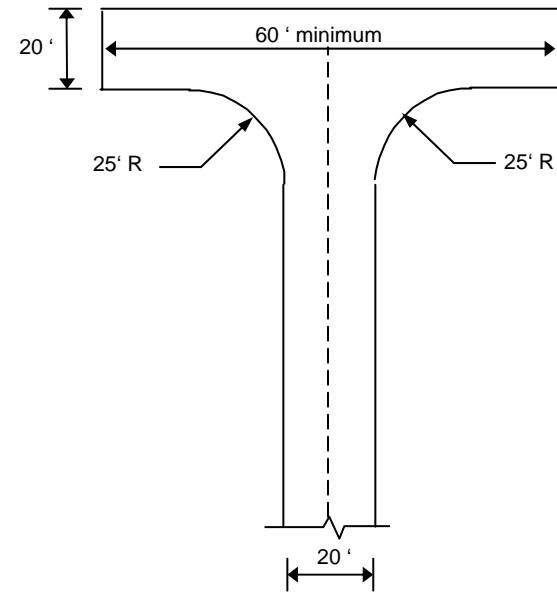

TYPE 3

### ACCESS EASEMENT TURNAROUNDS

Hammerhead turn-arounds (Type 2 and 3) may only be used on access easements/emergency vehicle access as per Section 12.53.010 or for temporary work area turn-arounds.

AccessEasement.doc

**DOUGLAS COUNTY  
DEPARTMENT OF  
TRANSPORTATION &  
LAND SERVICES**

REVISIONS	DATE

**ROADWAY  
STANDARDS**

**ACCESS EASEMENT  
TURNAROUNDS**

**FIGURE 4 - 2**

7/21/04

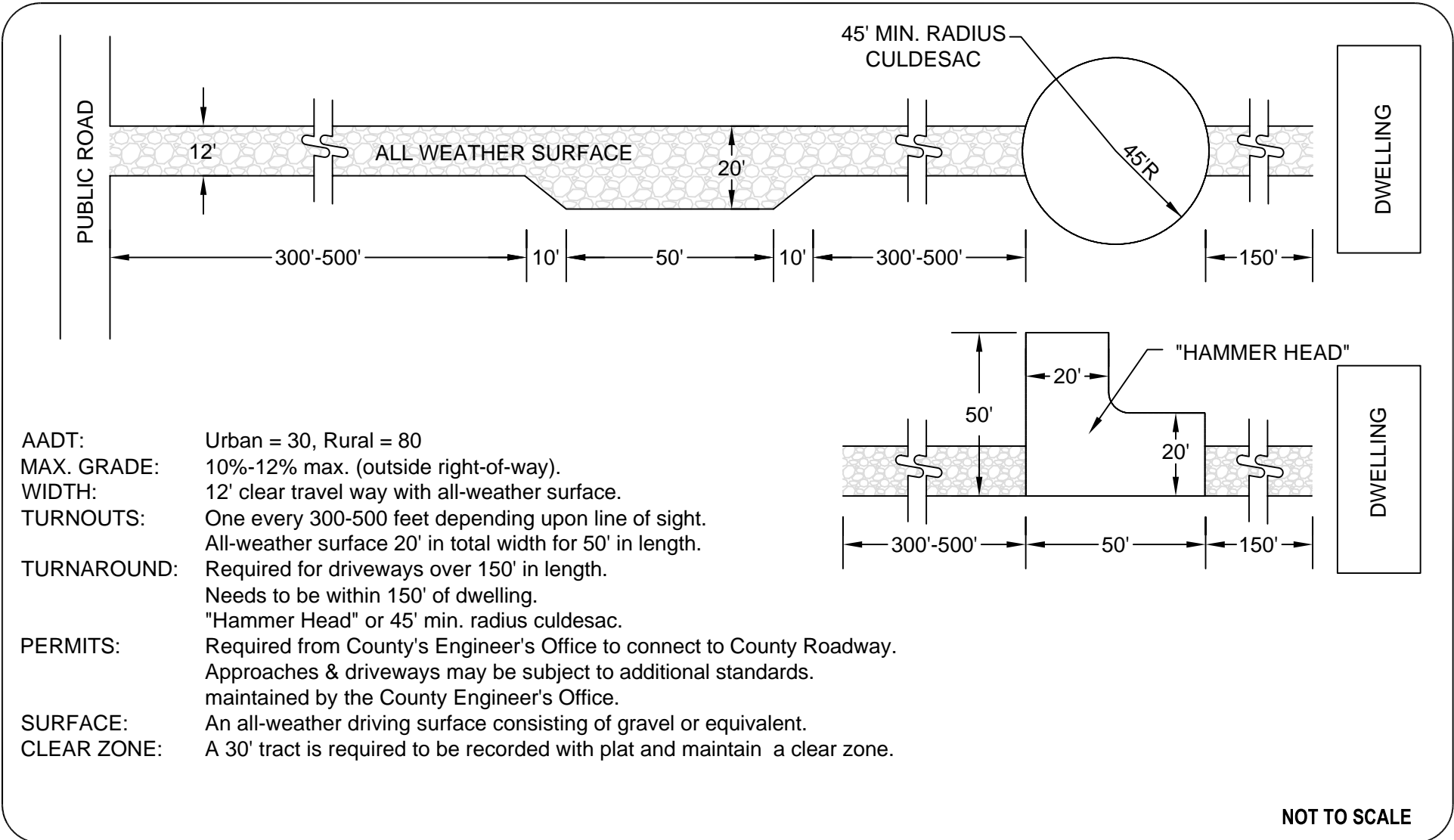

**DOUGLAS COUNTY  
DEPARTMENT OF  
TRANSPORTATION &  
LAND SERVICES**

REVISIONS	DATE

**ROADWAY  
STANDARDS**

**ACCESS EASEMENT  
FIGURE 4-3**

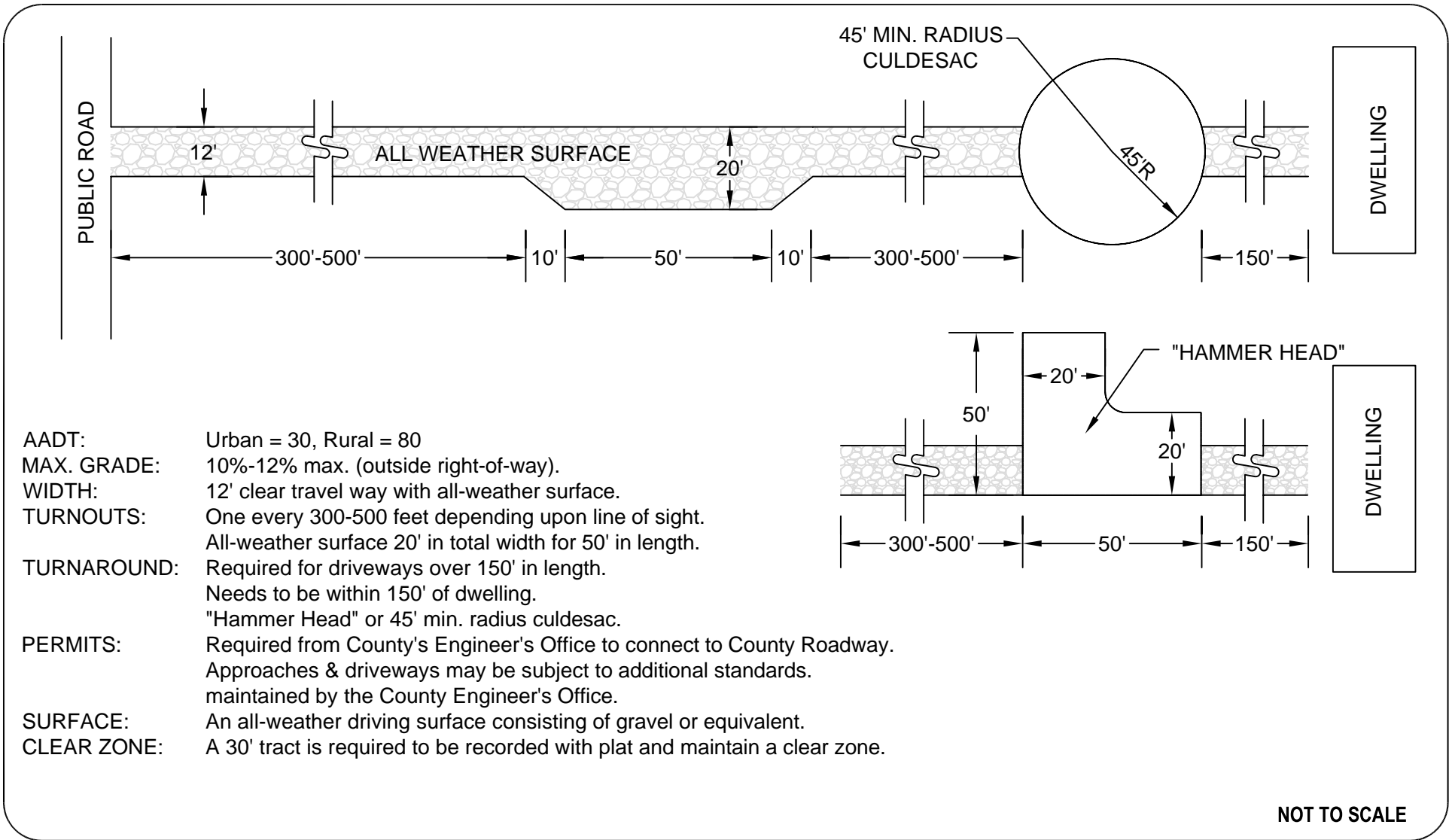

DOUGLAS COUNTY  
DEPARTMENT OF  
TRANSPORTATION &  
LAND SERVICES

REVISIONS	DATE

**ROADWAY  
STANDARDS**

**ACCESS EASEMENT  
FIGURE 4-3**

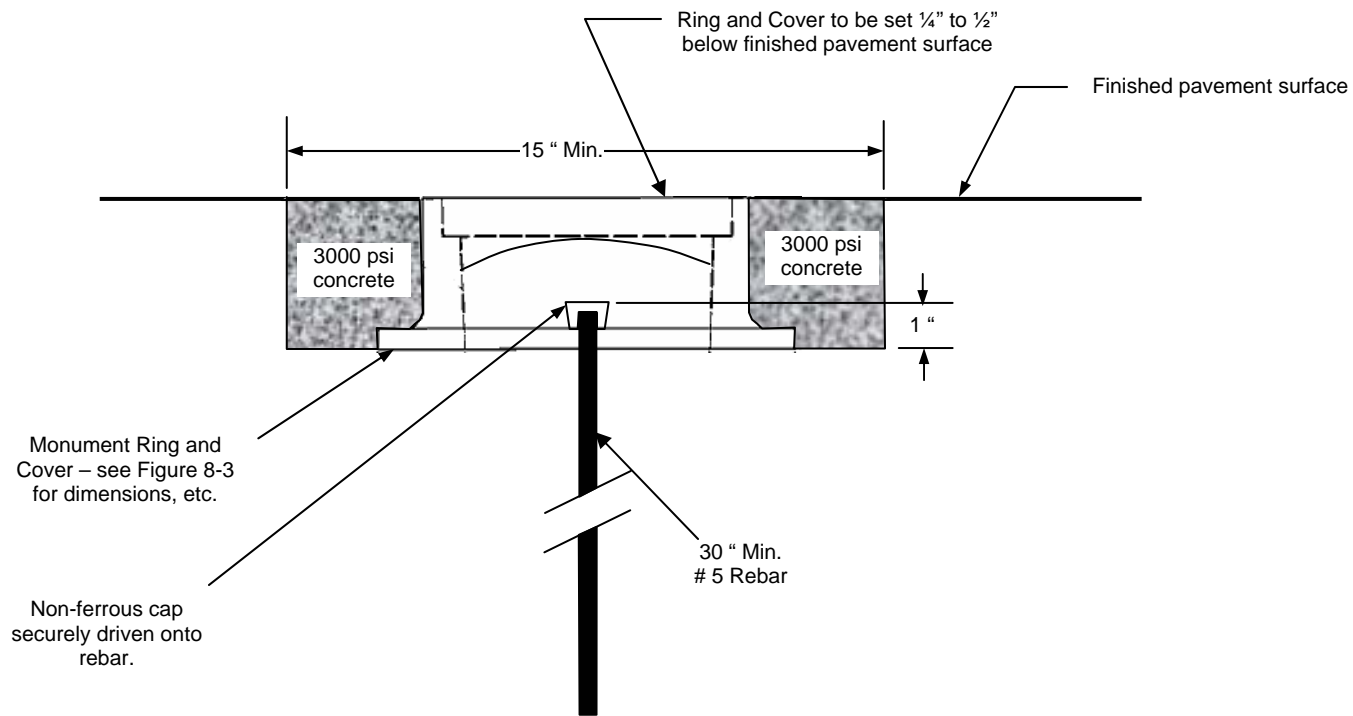

SurveyMon.doc

**DOUGLAS COUNTY  
DEPARTMENT OF  
TRANSPORTATION &  
LAND SERVICES**

REVISIONS	DATE

**ROADWAY  
STANDARDS**

**SURVEY MONUMENT  
IN ROADWAY  
FIGURE 8 - 1**

7/21/04

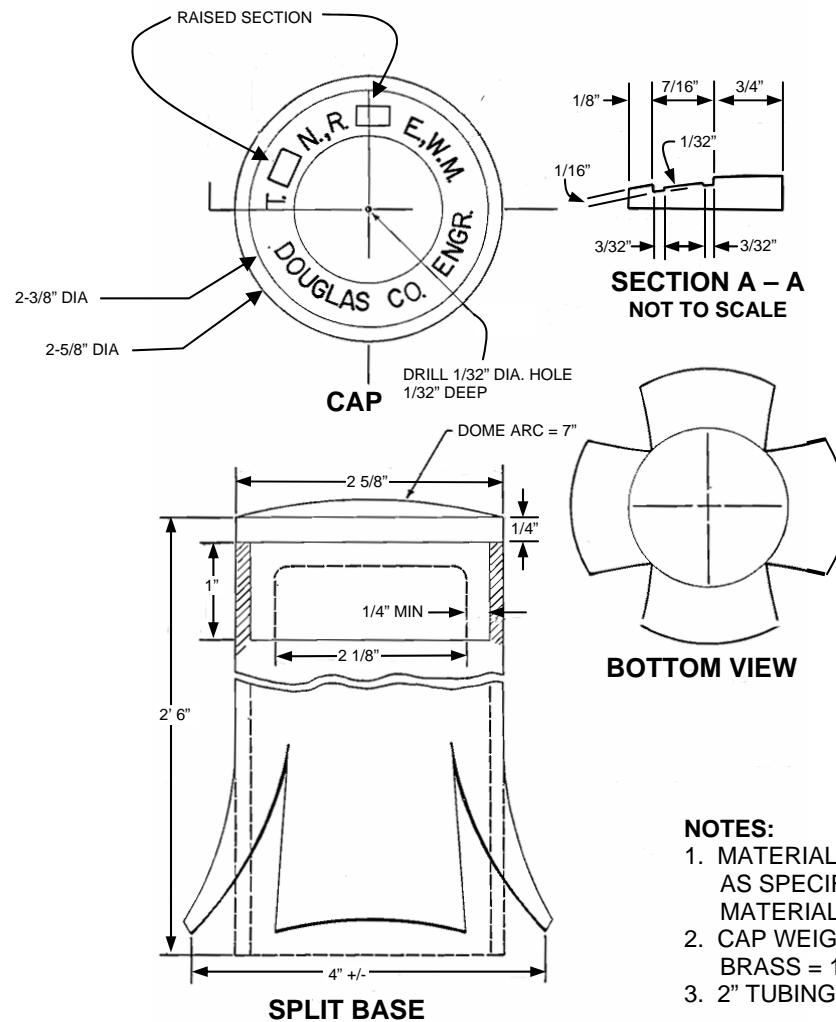

**NOTES:**

1. MATERIAL OF CAP – BRASS OR ALUMINUM AS SPECIFIED
- MATERIAL OF BASE – ALUMINUM
2. CAP WEIGHT : ALUMINUM = 6 OZ  
BRASS = 18 OZ.
3. 2" TUBING SUPPLIED BY OTHERS

SurveyMon2.doc

**DOUGLAS COUNTY  
DEPARTMENT OF  
TRANSPORTATION &  
LAND SERVICES**

REVISIONS	DATE

**ROADWAY  
STANDARDS**

**SURVEY MONUMENT 2**

**FIGURE 8 - 2**

7/21/04

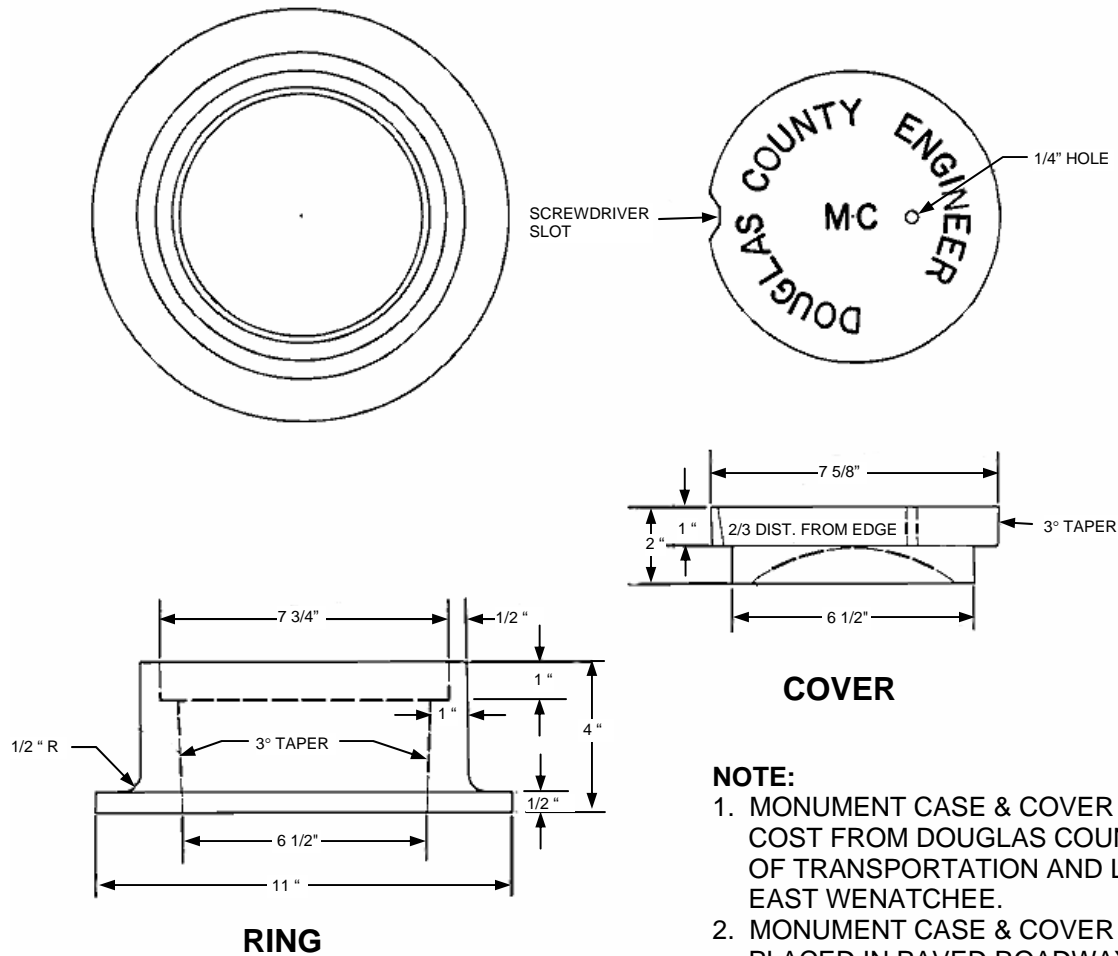

**NOTE:**

1. MONUMENT CASE & COVER ARE AVAILABLE AT COST FROM DOUGLAS COUNTY DEPARTMENT OF TRANSPORTATION AND LAND SURVICES, EAST WENATCHEE.
2. MONUMENT CASE & COVER TO BE USED WHEN PLACED IN PAVED ROADWAY.
3. SEE FIGURE 8-2 FOR REQUIRED CAP

SurveyMon3.doc

**DOUGLAS COUNTY  
DEPARTMENT OF  
TRANSPORTATION &  
LAND SERVICES**

REVISIONS	DATE

**ROADWAY  
STANDARDS**

**SURVEY MONUMENT 3**

**FIGURE 8 - 3**

7/21/04